

# 2010 STAFFORD MOTOR SPEEDWAY LATE MODEL DIVISION RULES

ALL RULE REVISIONS FOR 2010  
CHECK YOUR CORRESPONDING RULE BOOK FOR COMPLETE EXPLANATION  
LATE MODEL RULEBOOK

REV.1/1/10 TRACK RULE 6-4 PERSONAL SAFETY EQUIPMENT  
REV.1/1/10 20F- 4 GENERAL ENGINE REQUIREMENTS  
REV.1/1/10 20F- 5.9 INTAKE MANIFOLD ENGINE B  
REV.1/1/10 20F- 5.10.2 CARBURETOR SPACER ENGINE B  
REV.1/1/10 20F- 9 ENGINE EXHAUST SYSTEM ALL ENGINES  
REV.1/1/10 20F- 5.9 INTAKE MANIFOLD SPEC ENGINE (ENGINE C)  
REV.1/1/10 20F- 5.10.2 CARBURETOR SPACER ENGINE B  
REV.1/1/10 20F- 5.10.2 CARBURETOR SPACER SPEC ENGINE (ENGINE C)  
REV.1/1/10 20F- 16.1 FUEL CELL  
REV.1/1/10 20F - 5.12.2 AIR INTAKE ALL ENGINES  
REV. 1/1/10 20F - 12.3 SHOCK ABSORBERS  
REV. 1/27/10 20F - 2.1 BODIES  
REV. 3/19/10 20F -10.4 TRANSMISSION  
REV. 5/10/10 20F - 12.1 COIL SPRINGS  
REV. 5/10/10 20F- 12. 5 SPINDLES AND HUBS

MYLAPS AMERICA	<a href="http://www.mylaps.com">www.mylaps.com</a>	1-678-816-4000
Master Frequency List		1-207-571-9165
Racing Electronics	<a href="http://www.racingelectronics.com">www.racingelectronics.com</a>	1-800-272-7111
Hoosier Tire East		1-860-646-9646
Dave Lind Racing		1-800-562-9527
Reliable Welding & Speed	<a href="http://www.reliableweldingandspeed.com">www.reliableweldingandspeed.com</a>	1-888-225-7223
New England Racing Fuel	<a href="http://www.newenglandracingfuel.com">www.newenglandracingfuel.com</a>	1-860-673-9555

Track Frequency Channel #1	SK Modified@, Late Model	464.50000
Track Frequency Channel #15	SK Light, Limited L.M., D.A.R.E. Stock	461.13750

## PREFACE

The rules in this book are intended to make racing less expensive and keep competition as equal as possible. While these rules offer a good outline, every item cannot be covered by a written rule. If you come up with something not covered in the rules, **PLEASE ASK FIRST!**

All rules in the NASCAR Rulebook will be enforced with the following changes and additions. These rules are for Stafford Motor Speedway only with no expressed or implied agreement with any other speedway as to the interpretation, implementation and method of inspection by the technical inspectors and officials.

No equipment will be considered as having been approved by reason of having previously passed through inspection unobserved. No car will be considered as having passed inspection for the event until the finish is made official.

**NOTE:** All engine models, equipment changes, or modifications not specifically addressed in these rule books by Stafford Motor Speedway must be submitted to the track for consideration of approval on or prior to September 2, 2010 unless otherwise authorized by Stafford Motor Speedway to be considered for competition for the 2011 season. All equipment is subject to the approval of the track officials. Track officials may assess penalties including but not limited to weight, fines, points, or handicapping for cars, car parts, components, and/or equipment deemed as not in compliance with these rules. Car parts, components, and/or equipment will not be considered as having been approved by reason of having passed through inspection at any time or any number of times unobserved or undetected. Any car, car part, component, and/or equipment which does not conform to specifications or tolerances contained in the 2010 rule books or is not otherwise approved by Stafford Motor Speedway may not be used in competition in 2010. Any new part or component to be considered for approval for competition must be submitted to Stafford Motor Speedway. The owner/driver must provide all information and/or parts or components to Stafford Motor Speedway and must provide any part or components to be used as comparison items for inspection purposes.

**DEFINITION OF STOCK:** In the following Rules you will see the term OEM Stock used. This means Original Equipment Manufacturer. The parts must come on a standard production car. Special "Off-Road" or racing parts will not be permitted unless pre-approved. No carbon fiber or titanium engine, chassis or body parts unless approved by track officials.

**ILLEGAL ITEMS** - Absolutely NO removal of, alteration of, or covering of casting numbers, part numbers, manufacturers name, logo, insignia, etc., from any item on the race car. To do so makes a part illegal and will be treated as such. If you come up with a rare part that we cannot find listed for passenger car use, the burden of proof is on you. At any time you may be asked to remove a head, manifold or possibly an entire engine for inspection. Failure to comply will result in the same penalty as if it were illegal.

**INSPECTION** - All model, engine or equipment changes or modifications not specifically addressed in this rulebook must be submitted to Stafford Speedway for consideration of approval. All equipment is subject to the approval of Track Officials. Equipment will not be considered as having been approved by reason of having passed through inspection unobserved. Any equipment that does not conform to specifications or tolerances contained in this rulebook or is not otherwise approved by Stafford Speedway may not be used in competition.

**POST RACE INSPECTION**- Once a car has been presented to Stafford Technical Inspectors for post race inspection the entire car and all its parts become subject to inspection. This includes but is not limited to items designated for inspection following a particular event.

**Scales.** For purpose of post race inspection drivers must be seated in their car in a racing position with their helmet either on or placed on their lap at all times. No leaning or hanging on bars is permitted. The driver must remain in his/her car until it is removed from the scale area.

**ABSOLUTELY NO SMOKING IN THE FENCED IN TECH AREA.**

The rules in this book may be added to, deleted from or changed at any time with the only notice to be given at the event drivers meeting or via technical bulletin. All officials' decisions are final, non-appealable and non-litigable. Technical bulletins will be issued as needed.

**UPDATES** - All changes and updates made during the course of the season for the current rulebook will be posted to the Stafford Motor Speedway website. This will serve as the only form of official notification until the printing of next Stafford Motor Speedway rulebook.

**CONTINGENCIES** - Contingency sponsors are a valuable part of Stafford Motor Speedways program. Contingency stickers must be displayed for either product or monetary considerations. Each division will be notified as to what stickers are required to be eligible for contingency rewards. The stickers **MUST** be displayed on both sides of the car in such a manner as to be **EARLYLY VISIBLE** in a photograph.

## STAFFORD SPEEDWAY TRACK RULES

**NOTICE** Alcohol will not be permitted in the Stafford Speedway pit or paddock areas at any time. The consumption of alcohol before, during or after a race event in the pit or paddock areas is prohibited.

### SECTION 1-4

All NASCAR Rules will be enforced with the exception of the following STAFFORD SPEEDWAY TRACK RULES. These rules supersede any similar NASCAR Rules and are in effect for all auto racing events unless otherwise posted and/or announced prior to the event.

NOTE: Some Track Rules may not apply to touring divisions.

### SECTION 6 SAFETY

*Stock car racing is an inherently dangerous sport. Each Competitor assumes that risk when he or she participates in an Event. The risk of serious injury or death cannot be eliminated and in fact will always be present at a high level. Members are required to advise their spouses and next of kin, if any, of this fact. Although safety is generally everyone's concern, Stafford Motor Speedway cannot be, and is not responsible for all or even most aspects of the safety effort. That responsibility instead rests with the various participants in the Event(s) as follows.*

*All competitors are obligated to inspect the racing facilities, safety personnel and equipment, and conditions at the track on a continuing basis, before, during and after the event. Competitors must report to Stafford Motor Speedway management promptly any inadequacy in the facilities, personnel, equipment or conditions at the track.*

*PASSENGERS are not permitted in or on a racecar at any time. No one shall ride with any part of his or her body outside the racecar. No riding on trailers or car haulers anywhere on the speedway property.*

**NEITHER STAFFORD MOTOR SPEEDWAY NOR TRACK OFFICIALS CAN OR WILL BE RESPONSIBLE FOR THE ADEQUACY OF A COMPETITOR'S RACECAR, RACING EQUIPMENT OR RACING ACTIVITY TO ACCOMPLISH THIS PURPOSE.**

### SECTION 9 RACE PROCEDURE

1. All cars must go into the infield before turning into the off-track paddock gate except at the conclusion of the feature event. No right turn from the track to the paddock. All cars must go through the infield road after each warm-up session and qualifying event. After feature events cars may go directly into the paddock area without going through the infield. The first three (3) cars in the feature finish must report to victory lane. **DO NOT DO BURNOUTS OR DONUTS ANYWHERE ON THE RACE TRACK OR INFIELD AFTER THE FEATURE EVENT OR AT ANY OTHER TIME.**

2. The track crew, officials, wrecker or push truck drivers are not allowed to work on race cars on the track, infield, pit or paddock areas.

3. No car will be permitted to pass the caution vehicle unless instructed to do so by NASCAR Officials.

4. No car will be permitted on the track at any time without a hood.

5. All owners of cars that the oil pan cannot be removed with the engine in the chassis must have a carb flange lift plate or other device for the removal of the engine.

6. At no time shall a car be jacked up without jack stands with pads being placed under it except for normal tire changes during the race event. At no time shall a person be permitted to go under a car without jack stands. This rule applies to both the infield pit and paddock areas.

### **SECTION 9.5 HANDICAPPING Note: Some rules do not apply to DARE STOCK Division.**

**All drivers must complete a Number Application form before signing in.**

For all events your car must be signed in 45 MINUTES before the first heat race is scheduled. Once the line-ups are posted no additional cars may be added. If your car is signed in but does not arrive you may be credited with two wins for handicap purposes.

When you sign in your car state your division, assigned car number and the driver's name. If you bring two cars, one as a **BACK-UP CAR** you must decide and indicate which car will be your primary car when you sign in. Drivers will be handicapped on a 3-week money won system. For handicapping purposes regular feature event purses will be used. Any driver that misses an event will be credited with a regular feature win in money plus 1/2 feature win in money for handicapping purposes. Any driver disqualified from a feature event will be credited with a regular feature win plus 1/2-feature win in money for handicapping purposes. The top 18 drivers in points will be handicapped ahead of drivers not in the top 18 for the main feature only.

**For DARE Stocks, current season DARE Stock feature winners will not be able to be posted to start higher than 10th position in any remaining feature events. (EIRI)**

Note: For some events the top ten cars in points may be considered as pre-qualified. The car must still be signed in 45 minutes before racing starts to take advantage of being pre-qualified.

All alternate feature cars will be taken from the consolation event. If a car is disqualified from a heat additional cars will not be taken from heats but from the consolation or 'B' feature.

If in the opinion of the Racing Director a car is not competitive on a given night, he has the authority to deny that driver a front starting position. For additional handicapping information please ask handicapper for clarification.

## **PAST CHAMPION'S PROVISIONAL POSITION**

One additional starting positions have been established which will be available to the most recent Stafford Motor Speedway Champion who has not qualified for the starting field. *If a former Stafford Motor Speedway champion is not assigned this starting position, it will then be assigned to the next eligible driver who did not qualify for one of the original starting positions based on the current Stafford Motor Speedway championship point standings.*

## **PROVISIONAL POSITIONS**

Two additional starting positions have been established which will be available to the highest drivers in the current Stafford Motor Speedway Championship Point Standings who have not qualified for the starting field.

## **ROOKIE RULES**

- A. Rookie Rules apply to SK Modified®, SK Light Modified, Late Model, and Limited Late Models divisions. To be considered as a rookie you must not have competed in more than five, (5) feature events in this or a higher division at Stafford Motor Speedway.
- B. All cars driven by rookies must have a yellow stripe on the rear bumper. Rookies may not have another driver qualify a car for them.
- C. The current Rookie of the Year as determined from the previous season, will be awarded \$100 each event starting with the first event of the current calendar year and continuing each consecutive event until the total award amount for each division is distributed. To be eligible for the Rookie of the Year award the driver must attempt to qualify. If the current Rookie of the Year as determined from the previous season is not eligible for this award, the award will then be available to the next highest finishing eligible rookie driver in the previous season Rookie of the Year points standings.

## **SECTION 9.6 STARTING LINE-UP & RESTARTS**

If a car(s) drops out of the posted starting line-up, all cars in that row will move straight up to fill the spots in all events. No crossing over. If a restart occurs with ten, (10) laps or less to the end of the feature, all lapped cars will be removed from and started behind the lead lap cars in the restart line up.

## **SECTION 10.4 YELLOW & RED FLAG/LIGHT RULE**

The Yellow & Red Flag condition will be used for feature events where the yellow flag laps are being counted. If in the opinion of the officials the yellows are using up too many laps the red caution will be used. The laps will not count against the feature total but if you pit you will lose the amount of laps you are in the pits.

## **SECTION 10.8 CHECKERED FLAG - RACE END**

All FEATURE races will end with a GREEN, WHITE, CHECKERED unless in the opinion of the officials the track is no longer safe for racing.

## **SECTION 11.1 OFFICIAL SCORING**

SK Modifieds®, Late Models, SK Light Modifieds and Limited Late Models must have a scoring transponder assigned and attached to the racecar for practice or racing. (Please see installation specifications on page 7). All competitors will have 15 minutes after their feature event is announced and posted to file an inquiry. Once the inquiry is satisfied the official finish will be posted. No changes will be made once the finish is official.

## **FOR SALE SIGNS**

For Sale Signs are not permitted on cars in feature events.

**BACK-UP CARS** – Separate number registration is required for back-up cars. No cars competing in the same division will be allowed in the paddock area with the same number.

## **INFIELD PITTING**

1. Infield pitting will be used for all SK Modified and Late Model features. All crewmembers that go to the infield pit area will be required to have a NASCAR license. During race conditions, any crewmember who steps into the car servicing area must wear a helmet. All people on the infield must wear long pants with a minimum short sleeve shirt and closed toe footwear at all times. You must pit in your proper pit stall.
2. NASCAR pit rules will apply including the amount of crewmembers over the wall, etc. A stop & go official will be at the exit of pit road only. You may not enter pit lane until the pace car picks up the leaders and the pit road is opened. You may pull up to but not pass the pace car.
3. No crewmember may go into the pit box until the car has come to a complete stop.
4. Pit stalls will correspond to the starting positions of the feature line up.
5. The speed limit on pit road at all times including qualifying and practice will be 25 MPH. Speeding in the pits may result in disqualification.
6. Absolutely no fueling of cars on the infield. No gasoline containers will be permitted on the infield.
7. Wreckers and push trucks are not permitted to bring pit materials to the infield to set up your pit stalls.
8. All cars out of the event must go behind the wall on the infield.

## **6- 4 PERSONAL SAFETY EQUIPMENT**

See NASCAR WEEKLY SERIES RULE BOOK

### **20F - 3.2.3 Side Window Glass / Window Screen**

A. All door window glass must be removed. A window screen must be installed in the left side door window opening and should be positioned to cover the entire window opening. Window screens should not be used beyond *three (3)* years from the date of manufacture. The window screen must be a rib type, made from minimum 3/4 inch, maximum one (1) inch wide material with a minimum one (1) inch and a maximum 2-1/4 inches square opening between the ribs. Window screens are recommended to meet the SFI 27.1 specifications. The minimum window screen size must be 22 inches wide by 16 inches high. The forward edge of the window screen, when in the closed position, must be in line or forward of the steering wheel. All window screen mounts must be a minimum 1/2 inch diameter solid steel rod on the bottom and a minimum one (1) inch wide by 3/16 inch thick flat steel or a minimum 1/2 inch diameter solid steel rod on the top, with mounts welded to the roll cage. The window screen, when in the closed position, must fit tight and be secured with a lever-type quick release latch acceptable to Track Officials. The lever must be secured by a detent ball in the lever and may be supplemented by a Velcro® fastener only - pins or clips will not be permitted. The latch must be mounted at the top in the front to roof bar (#3) or at the top of front roll bar leg (#2A) near roof bar (#3) and release from the inside.

### **6- 4-1 HELMETS- HEAD AND NECK RESTRAINT DEVICES**

See NASCAR WEEKLY SERIES RULE BOOK

### **6- 4-2 SEAT BELTS**

See NASCAR WEEKLY SERIES RULE BOOK

## 6- 4-3 SEATS

See NASCAR WEEKLY SERIES RULE BOOK

### SCORING TRANSPONDER LOCATION

Transponder mounting brackets will be installed on the inside (or outside) of the right rear frame rail. The round post of the bracket must be on top and the square tab on the bottom flush with the lower edge of the frame rail. The bracket must be mounted with its center line exactly 12" to the rear of the rear axle centerline and must be completely vertical to the ground. Keep exhaust directed away from transponder.

Transponders are available from  
MYLAPS AMERICA  
32 Highlands Parkway, Suite 104  
Smyrna, GA 30082  
Tel 678-816-4000 Fax 678-816-4001

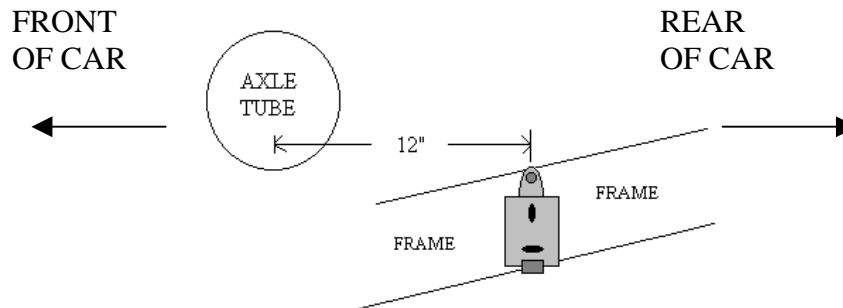

### LATE MODEL DIVISION

**ALL 2010 NASCAR WHELEN ALL AMERICAN SERIES RULES FOR THE LATE MODEL STOCK CAR DIVISION WILL BE ENFORCED FOR THE STAFFORD LATE MODELS WITH THE FOLLOWING CHANGES AND ADDITIONS.**

**DRIVER ELIGIBILITY** - All drivers must have a NASCAR CHD (CHARGER DIVISION DRIVER) or higher license. Drivers competing in the LATE MODEL division at Stafford Speedway will not be permitted in the SK LIGHT MODIFIED, LIMITED LATE MODEL, or D.A.R.E. STOCK division on the same event date. Drivers must be a minimum 16 years of age to compete in the Late Model division.

**20F- 1 COMPETING CHASSIS** - American made chassis with a minimum of 108" wheelbase as factory listed for that year and model. No Firebirds, Camaros, Mustangs or two passenger sports cars. No convertibles, station wagons, or use of their frames for other models. Body may differ from frame and engine but engine and frame parts must be from the same corporate line (i.e. GM, Ford, Chrysler). If you are in doubt about the eligibility of a make or model, **CHECK BEFORE YOU BUILD IT!**

**20F- 2.1 BODIES** - All bodies must be NASCAR approved. See NASCAR Rulebook Late Model Stock Car Division for approved bodies and additional body specifications. Original dimensions of all bodies must remain as manufactured except for changes which may be necessary for tire clearance. All aftermarket body and trim parts must be acceptable to Track Officials.

*All Late Models will be subject to the Nascar LMS body type measurements. Track officials will use LMS type templates to insure the measurements from car to car are the same. All vertical measurements from the NASCAR Rule Book will be plus one (1) inch. With the exception of the 18 1/4" min deck lid length all other measurements that say minimum or maximum shall be considered as exact for this division. Tolerance will be built into the templates from the manufactures. Any other models must be approved by Stafford Motor Speedway. All vertical body measurements will be done by ride height.*

Older Late Models and Limited Late Models with higher roof heights will be adjusted according to the rule.

# LMSC BODY MOUNTING GUIDELINES

## IMPALA - FUSION - CHARGER

Five Star Late Model Stock Bodies are designed to meet a 48" roof height, up to a 65" treadwidth, a 46" front overhang and a 47" rear overhang, and up to a 106" wheelbase.

When mounted using the dimension guidelines at right and the recommended template set, these bodies will meet the specifications as regulated by sanctioning body templates and inspection devices.

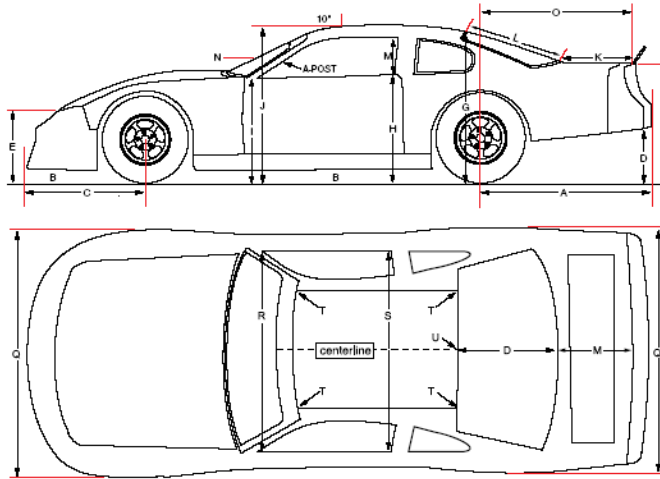

## NASCAR DIMENSION GUIDELINES

A REAR OVERHANG (MAX): base of spoiler at centerline to axle centerline	52"
B NOSE/SIDE PANEL CLEARANCE (MIN): from ground	4"
C FRONT OVERHANG (MAX): on centerline	46"
D BUMPER COVER HEIGHT (MAX): from ground	15½"
E NOSE HEIGHT (MIN): at nose & hood seam	23"
F QUARTER PANEL/BUMPER COVER HEIGHT: at bumper cover/deck lid intersection	34½"
G ROOF HEIGHT, REAR (MIN): at center rear edge	45½"
H DOOR HEIGHT: at rear	33"
I FRONT FENDER HEIGHT: at A-post (MAX)	33½"
J ROOF HEIGHT (MIN): 10" back from windshield, on centerline	48"
K DECK LID LENGTH (MAX): at center, from base of spoiler to rear window	23½"
L REAR WINDOW LENGTH: on centerline	31½"
M SIDE WINDOW OPENING (APPROX): at B-post	15"
N WINDSHIELD ANGLE: at center/at roof windshield post	26°
O REAR OVERHANG (MAX): base of spoiler at centerline to axle centerline	47"
Q BODY WIDTH (MAX): at wheel wells	must not extend past tires
R DOOR TO DOOR WIDTH (measured through car): at A-posts and inside edges of doors	67"
S DOOR TO DOOR WIDTH (measured through car): at B-posts and inside edges of doors	65½"
T ROOF HEIGHT, CORNERS: at body lines	front: 45⅛" rear: 44¼"
U ROOF HEIGHT, REAR: at centerline	45½"

## ROOF MOUNTING

A properly located roof is essential for a properly mounted body.

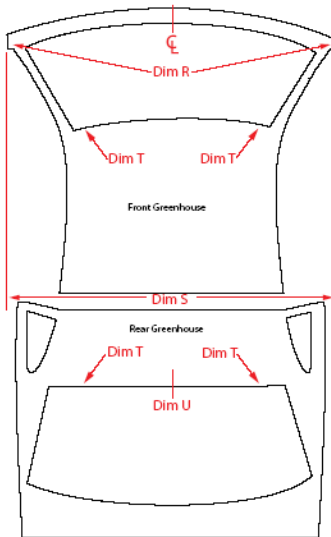

This drawing shows roof corner dimensions to help you properly locate the roof. Once the roof is located, confirm that highest point on the roof (Dim. H) is 48". This dimension is measured 10" back from the windshield.

### NOTES:

1. DIM R is measured at the A-posts and inside edges of the doors.
2. DIM S is measured at the B-posts and inside edges of the doors.
3. The T and U dimensions are taken at the edge of the roof (not on the ledge where the window sits) and are measured from the floor up. Look for the scribe line indicators in the window bed for the locations to measure dimension T.

*You can always count on Five Star to have the panels and components you need for immediate shipment through our nationwide dealer network, or direct from our factory warehouse.*

## 12 LMSC BODIES

**20F- 2.2 OVERALL CAR WEIGHT** - All specified weight requirements will be with the driver. The minimum weight at all times will be **3000** pounds. No car will be allowed to have more than **55%** of the total weight as the left side weight. All weight must be bolted to the inside of the frame rail and above the lowest edge of the frame where weight is mounted. **Any car found to be under the minimum overall car weight allowance will be penalized one position for every pound under the minimum weight. This does not apply to left side weight requirements.**

**20F- 2.3 ADDED CAR WEIGHT** - Added weight must be in block form of no less than five (5) pound blocks (no pellets) of magnetic steel or lead only. Added weight must be securely bolted to the frame rail and painted white with the car number stenciled in black. No added weight will be permitted inside the driver's compartment. Weight must be welded in a box or attached with two or more grade '8' bolts minimum 7/16 dia.

**20F- 2.4 CAR WEIGHTS AFTER RACE** - Nothing may be added to or taken from the car to make total or left side weight. Gas, oil or water may not be added. Wheels and tires cannot be changed, but an amount equal to one half of one percent (.5%) of the gross weight will be added for loss in weight due to race wear.

**20F- 3 DETAILED BODY REQUIREMENTS** – Steel aftermarket replacement bodies may be used in place of stock. Hood and roof may be made of fiberglass. Steel front fenders may be replaced with plastic. Fiberglass front fenders are not permitted. Body must be, straight and stock, mounted in the stock location on the frame. No lowering, chopping, channeling or streamlining of any body parts or roof. Stock window openings must be maintained. No fiberglass replacement parts unless noted elsewhere in the rules. All exterior chrome trim ornaments, outside mirrors and door handles must be removed. Replacement body parts must meet NASCAR templates. No body skirts or lower body rocker panel flares. Rolled under rocker panels are recommended. Rear quarter panels may be plastic or steel only.

**20F- 3.1.1 FRONT AIR DAM** - Approved air dams must maintain **5" ground clearance.**

**20F- 3.1.2 REAR SPOILERS** - A non-adjustable freestanding clear polycarbonate glass solid rear spoiler is permitted. Spoiler will be a maximum of **5" in height and a maximum of 54"** in width. **At least 3.50" of the rear spoiler must be clear Polycarbonate glass at all times.** Spoiler must be placed in the center and at the rear edge of the trunk lid. **The spoiler angle must be set between 50 & 60 degrees.** No side gussets. All spoilers are subject to track approval.

**20F- 3.2 GLASS** - No side windows allowed. Full windshield is required made of clear glass or 1/8" polycarbonate glass. Windshield must maintain stock angle and fit template. Windshield must have two safety straps on the inside and out. No cracked windshields allowed. All lights and lenses must be removed from the car. Headlight and taillight openings must be covered. Headlamp and tail lamp decals are recommended for aesthetic reasons. No tinted side, quarter or rear windows.

**20F- 3.2.2 REAR WINDOW** - Full clear polycarbonate glass rear window is required. Two 1" straps are required inside and outside. Stock angle must be maintained. No tinted glass.

**20F- 3.2.3 SIDE WINDOW GLASS/WINDOW SCREEN** – All door window glass must be removed. A nylon window screen must be installed in the left side door window opening and be positioned to cover the entire window opening. The window screen must be rib type, made from minimum 3/4 inch, maximum one (1) inch wide nylon material with a minimum one (1) inch and a maximum 2/4 inches square opening between the ribs. The minimum window screen size must be 22 inches wide by 16 inches high. All window screen mounts must be a minimum 1/2 inch diameter solid steel rod on the bottom and a minimum one (1) inch wide by 3/16 inch thick flat steel or a minimum 1/2 inch diameter solid steel rod on the top, with mounts welded to the roll cage. The window screen, when in the closed position, must fit tight and be secured with a lever-type quick release latch acceptable to Track Officials. The lever must be secured by a detent ball in the lever and may be supplemented by Velcro® fastener only – pins or clips will not be permitted. The latch must be mounted at the top in the front to roof bar (#3) release from the inside.

**20F- 3.2.5 REAR VIEW MIRROR** - One (1) rear view mirror that must be mounted at the top of the windshield no larger than 8" X 2". No multi-image or side mirrors. Oversized mirrors may be blacked out by the use of paint only, to obtain the 8" X 2" maximum reflective area. Any size or type of spot mirror is not permitted in any location.

**20F- 3.3 DASHBOARD** - Stock unit may be removed but must be replaced with sheet steel, a minimum of 24-gage (0.025 inch thick), of similar design, and the full width of the body. Per NASCAR rulebook, all cars should have a removable inspection panel with a minimum size of 10" (ten) by 10" (ten) or 8" (eight) by 18" (eighteen) on top of the dash on the driver's side for inspection of all wiring under the dash panel.

#### **20F- 3.4 FIREWALLS**

**A.** Front firewall must be in stock location and be made of minimum .031" metal with all holes covered using sheet metal a minimum of .031" thickness. Aluminum is not permitted. The front firewall must extend down to the top of the frame.

**B.** Rear firewall must be made of minimum .031" magnetic sheet metal securely installed over the rear seat back brace and top shelf or "hat rack", completely closing off the trunk compartment.

**C.** The top shelf or "hat rack" must be positioned horizontal and approximately level. At a maximum of 30-inches from back to front, the top self or "hat rack" must angle downward approximately 30-degrees and continue downward attaching to the #6 bar or lower.

**D.** The stock floor pan may be replaced with minimum .031" magnetic sheet metal bent similar to the original configuration. Any part of the passenger side floor pan higher than the top of the frame rail is not permitted. The passenger side floor pan may come straight across from a maximum height of the top of the frame rail, to the transmission tunnel. The floor must be sealed to the bottom of the door on both sides of the car. The rear seat area must seal to the rear firewall.

**E.** The transmission tunnel shape may be altered however must remain in original center position (equal distance from frame rails to either side of the tunnel) and within 1-inch of original height. Additionally the transmission tunnel must remain within 2-inches of stock width.

**F.** Door bars may not be covered on the interior of the car and must be visible for inspection from the inside of the car.

**G.** Absolutely no closing in of passenger compartment next to or behind driver.

**20F- 3.5 DOORS** - Doors may be steel or aluminum. External nerf bars may be used if no larger than 1" round tubing. Bars must be "skin" tight and painted the same as the body panel it is attached to. Bars must be at centerline of the front and rear tire. No bars behind rear wheels. Ends must be turned into and go through the body or bolted at the end of the bar with a flush bolt that goes through the body to an interior bar of the same length as the outside bar to prevent hooking. The outside bar must have the ends rounded. No spreading or narrowing of body. Replacement doors must have stock contour. No slab sided cars.

**20F- 3.6 FENDERS** - Front fenders and rear quarter panels may be either steel or plastic.

**20F- 3.7 GRILLES** - Grill openings must remain stock for body run.

#### **20F- 3.8 HOODS, ROOF**

**A.** Hoods may be made of steel, aluminum or fiberglass. The hood and scoop must seal tight to the fenders and windshield. Hood must be in place at all times

**B.** Hood must be held closed with quick release pins. Hinged hoods are permitted.

**C.** No holes or functioning air scoops allowed. Hoods must lay flat.

**D.** No openings for air to the carburetor or breather are permitted.

**E.** All roofs must be the same size and shape of a production roof. Steel or fiberglass roof permitted. Roof panels must be permanently mounted in the stock position the same as a stock production roof for the make and model car being used.

**20F- 3.9 REAR DECK LIDS/TRUNKS** - The rear deck lid / trunk may be steel or aluminum. Fiberglass is not allowed in these areas. The rear deck lid must maintain the same dimensions, angles and bodylines as the stock production car. Lid may be held closed with quick release pins. Complete taillight panel and bumper covers must be run. No flat back cars. Taillight decals are recommended.

**20F- 3.10 BUMPERS/BUMPER COVERS** – The bumpers/bumper covers must be acceptable to Track Officials and meet the following requirement:

- A. The front and rear bumpers and/or bumper covers must be installed in the same location as far as height, width and depth as a stock factory production bumper.
- B. Magnetic steel tubing must be used to reinforce the front and rear bumper covers. The tubing must not be exposed and must remain behind the bumper covers.
- C. The front and rear bumpers/bumper covers must be solid. Holes will not be permitted .
- D. All front and rear bumper covers must be painted the same color as the car including bolts and rivets

**20F- 3.11 IDENTIFICATION** – Refer to 2009 NASCAR Whelen All-American Series Rule Book. Roof numbers must read from passenger’s side of car. Stafford Motor Speedway reserves the right to assign number colors. Numbers must be present and visible for all events including practice sessions.

**20F- 3.12.1 BODY TEMPLATES** - Templates may be used to check any cars, which have questionable, body dimensions or configuration. Decision of Track Officials is final.

**20F- 4 GENERAL ENGINE REQUIREMENTS** - Engine must be OEM cast iron V8 production block, heads and intake manifold. Unless otherwise listed below. The ONLY approved engine for GM is the CHEVROLET 350, FORD is the 351 CLEVELAND or WINDSOR, MOPAR is the 360. No de-flashing, grinding, welding or painting of any internal area. Maximum overbore for Chevrolet and Ford is .045". Maximum overbore for MOPAR is .030"

<b><u>MOTOR TYPE:</u></b>	<b><u>COMPETITION ENGINE (NON-SPEC) ENGINE-A ***</u></b>	<b><u>COMP/D ENGINE NON-SPEC short block w/SPEC HEADS &amp; INTAKE - ENGINE-B **</u></b>	<b><u>LATE MODEL SPEC ENGINE ENGINE-C **</u></b>
<b><u>MAX STATIC COMPRESSION RATIO:</u></b>	<b><u>11.5 to 1</u></b>	<b><u>10.3 to 1</u></b>	<b><u>10.5 to 1</u></b>
<b><u>INTAKE:</u></b>	<b><u>2-BARREL CAST-IRON ++</u></b>	<b><u>4-BARREL ALUMINUM EDELBROCK 2101</u></b>	<b><u>4-BARREL ALUMINUM EDELBROCK 2101</u></b>
<b><u>HEADS:</u></b>	<b><u>461, 462, 492</u></b>	<b><u>DART-10024266</u></b>	<b><u>DART-10024266</u></b>
<b><u>MINIMUM COMBUSTION CHAMBER VOLUME</u></b>	<b><u>60cc</u></b>	<b><u>65cc</u></b>	<b><u>62cc</u></b>

**Note:**

**\*\* Indicates that Sunoco 260 GTX is the only approved Fuel for these motor types.**

**++ Indicates that you must refer to rule 20F-5.9 for specifications.**

**\*\*\* indicates that Sunoco Supreme is the only approved fuel for this motor.**

**All Stafford Motor Speedway Late Model competitors will be required to run a sticker in the Left hand corner of windshield to indicate type of Engine being used in competition.**

**Engine Type - A A max static compression ratio of 11.5 to 1 will be allowed on the current non-spec Stafford Late Model Motor with the "492" , "461" , or the "462" type heads with a minimum 60cc combustion chamber.**

**NOTE: THE ONLY FUEL THAT WILL BE APPROVED FOR ENGINE TYPE – A WILL BE SUNOCO SUPREME.**

**ENGINE TYPE –A WILL BE DISCONTINUED AFTER THE 2010 RACING SEASON.**

**Engine Type -B The current non-spec Stafford Late Model Motor equipped with the Dart Heads in spec form except for combustion chamber volume , and a second generation 2101 aluminum intake. Will have a max static compression ratio of 10.3 to 1 with a minimum 65cc combustion chamber. This motor will be required to run the Sunoco 260 GTX fuel only.**

**Engine Type -C The Spec Motor will maintain a static compression ratio of 10.5 to 1 with a minimum 62cc combustion chamber on the Sunoco 260 GTX fuel.**

**20F- 5 DETAILED ENGINE REQUIREMENTS FOR LATE MODEL ENGINE-A**

**20F- 5.1 ENGINE LOCATION**

A. Engine must be in the stock location for a V8 in the chassis being run. Stock engine location is deemed to be when the distance between centerlines of the forward most fuel pump to engine block mounting bolt and the upper idler-arm to frame mounting bolt measures 8.75” inches +/- .25” inch so long as said bolts are deemed to be in stock, un-altered, factory locations.

B. The front, centerline of the crankshaft must be no less than 12 3/4 inches from the ground with the car’s frame set on five (5”) inch high blocks under all four outer corners of the frame.

**20F- 5.5 PISTONS/RODS ENGINE A&B -**

A. Any flat top three (3) ring round aluminum piston with three (3) rings in place will be permitted. Valve reliefs for valve clearance only may be cut into the pistons. All three rings must be of magnetic steel. No portion of piston may protrude above the top of the block. No self-centering connecting rod type pistons. (Rods must align off the crankshaft rod journals). All three rings must be of flag magnetic steel. (No Dykes type rings).

The minimum ring thickness permitted is as follows:

Compression rings .043 inch Oil ring assembly 3.0 mm

NOTE: WHEN USING DART HEADS AS REPLACEMENTS FOR THE CURRENT VERSIONS, YOUR

**PISTONS MUST MAINTAIN A MINIMUM FLY CUT OF .150" Intake & .100" Exhaust. NO EXCEPTIONS.**

**B.** Only magnetic steel piston pins maintaining a minimum diameter of .0927 inch are permitted. *They can only be contained by bushings only. (No bearings of any type) Full floating pins are permitted. No coating of wrist pins. (DLC, etc.).*

**C.** Piston pin holes must be in a fixed location in the piston and connecting rods.

**D.** Only two-piece insert style connecting rod bearings are permitted.

**E.** Only solid magnetic steel stock type connecting rods are permitted. Hollow beam connecting rods are not permitted. All after-market connecting rods must be steel sportsman rods. Only normal engine balancing and the use of after-market bolts and nuts are permitted. No de-burring, de-flashing, polishing, grinding or lightening. Billet connecting rods are not permitted. All rods must maintain the minimum/maximum rod lengths listed below:

MANUFACTURER	MINIMUM	MAXIMUM
Dodge	6.000	6.250
Ford "Cleveland"	5.778	6.250
General Motors	5.700	6.250

All connecting rods of an engine must be the same length.

**F.** Titanium and stainless steel connecting rods are not permitted

**G.** Minimum weight for piston, pin, ring, bearing and rod assembly is **1075 grams.**

**20F- 5.5.4.1 OIL PAN ENGINE-A** - NO dry sumps, external oil pumps or tanks or accu-sump systems allowed. Windage trays of any type will be allowed. Oil coolers are allowed. Only OEM in the pan type oil pumps are permitted. No pumps of any type may be used in the evacuation system.

**20F-5.5.4.2 OIL PAN ENGINE-B** -*NO dry sumps, external oil pumps or tanks or accu-sump systems allowed. The only oil pans that will be permitted are the MOROSO #12312 and the Canton #11-122. Oil coolers are allowed. Only OEM in the pan magnetic steel type oil pumps are permitted. No pumps of any type may be used in the evacuation systems. A one (1) inch inspection plug may be installed in the front of the pan, Moroso P/N MOR23970. This is to allow NASCAR Officials access to inspect connecting rods and crank shaft. This is optional but highly recommended.*

**20F- 5.6 HEADS ENGINE A - OEM CAST IRON.** The only **CHEVROLET** heads allowed will be the "492" castings or the "old style 461 or 462 type heads". Angle plug, Bow-tie or Vortec heads are not permitted. Intake valve must be a maximum of 2.02". Exhaust valve must be no larger than 1.60". **FORD CLEVELAND** or **WINDSOR** must run heads of two barrel design that came on a passenger vehicle, with a maximum intake valve of 2.05 and exhaust valve of 1.66. **FORD** Motorsports heads are not permitted. The **MOPAR** permitted head is the passenger car version of casting number 3418915 with a maximum intake valve of 2.02 and exhaust valve of 1.60. W2 or TA heads are not permitted. **IMPORTANT** -All **CHEVROLET** and **FORD** heads must have a minimum of 60cc combustion chambers. **MOPAR** must have a minimum of 64cc combustion chambers. When heads are checked at the track you will be responsible for cleaning and carbon removal to make the respective cc limit. The only modifications **ALLOWED** will be the installation of valve guide sleeves and milling of the gasket surfaces, however angle milling, changing the angle of the head gasket surface in relationship to the rest of the head, is not permitted. Additionally altering the position or angle of the valve guide is not permitted. The addition of screw-in studs, guide plates, valve spring seats, optional valve seals, Poly-Locks or jam-nut devices are permitted. The only machining of valve guide bosses allowed is for seals only. Coolant return lines are allowed to be placed on the ends of the heads. No lines will be allowed on the sides of the head. Any other heads must be approved before being used. All other head modifications **ARE NOT ALLOWED** including but not limited to: Porting, polishing, ANY grinding in ports or combustion chambers, chemical milling, glass beading or removal of any flashing or casting marks. No welding or sectioning. No internal modifications of any kind including painting or Teflon coating. No more than two intake-mounting holes may have HeliCoils. Intake or exhaust manifold mounting holes may not be added or relocated. Holes must take standard intake manifold bolts.

#### **20F-5.6-1 HEADS FOR LATE MODEL ENGINE-B**

The Dart head part # 10024266 will be permitted on the current Stafford Late Model motor, but only in the Spec motor configuration *while maintaining a minimum 65 cc combustion chamber, and will be required to run the Sunoco 260 GTX with no exceptions!* REFER TO LATE MODEL SPEC ENGINE RULE SECTION 20F-5.6, HEADS, FOR COMPLETE SPECIFICATIONS, **MINUS THE COMBUSTION CHAMBER CC WHICH WAS STATED ABOVE.** This includes but is not limited to, port volumes, Valves, Valve Springs, locks, retainers, bowl area "ball" check , & all external dimensions. .

**Head gasket surface milling tolerance for Late Model is 0.00" to 0.050" from true 23.00 degrees of stock valve position.**

**VALVES ENGINE A** - All valves must be identical in appearance and construction as an OEM type valve. No air directional devices will be permitted on any of the valve surfaces. Valve stems must have a minimum diameter of 11/32 inch. Stainless steel replacement valves are permitted. Valve lifters can weigh no more than **98 grams.**

**VALVE JOB ENGINE A** - Three (3) angle valve jobs are permitted. When cutting the valve seat angles, no stone or grinding marks are permitted above the bottom of the valve guide. All cutting in reference to the valve job must be centered off the centerline of the valve guide. Upon completion of the valve job, the bowl area under the valve seat down to the bottom of the valve guide should still be the same configuration as far as shape and finish as it was from the manufacturer. Surfaces and/or edges where the cutter or stone has touched must not be polished. No hand grinding or polishing is permitted on any part of the head. Unshrouding of valves is not permitted.

**VALVE SPRINGS & RETAINERS ENGINE A** - OEM type single steel valve springs with damper and steel retainers allowed. Valve springs must retain all stock OEM replacement passenger car dimensions. No barrel wound or conical wound springs will be allowed. ALL windings must be parallel. Stock diameter spring must be used. Valve spring retainers must be OEM steel or stock or stock replacement steel only. Double valve springs with a max diameter of 1.450" will be allowed. Valve springs must have a height of 1.750" min to 1.080 max. No lightweight retainers will be allowed.

#### **20F- 5.7 CRANKSHAFT ENGINE A&B -**

**A.** Only stock production OEM crankshafts allowed. The main and rod journal size must be stock for the block being used. Original bore and stroke combination must be maintained. The maximum allowable stroke tolerance for Chevrolet and Ford will be +/- .015". Mopar will have +/- .005. Minimum main journal size .020 under stock. Minimum rod journal size .030 under stock.

**B.** After-market crankshafts, knife-edge crankshafts, small journal crankshafts will NOT be permitted.

**C.** NO machining or polishing of the crankshaft counterweights allowed. **NORMAL** engine balancing will be the **ONLY** acceptable modification that can be performed on this component. No painting or Teflon coating. NO drilling of rod journals.

- D. Minimum crankshaft weights are Chevrolet engines **50 lb.**, Ford and Chrysler **54 lb.**  
E. Only standard OEM magnetic steel elastomer type harmonic balancers will be permitted

**20E- 5.8.1 CAMSHAFT ENGINE A&B** - Only magnetic steel camshafts will be permitted. The maximum camshaft bearing journal size must not be more than **1.875" (475mm)**.

- A. ANY type chain will be permitted. Belt-drive and gear-drive systems will not be permitted.  
B. Only production sleeve type bearings will be permitted and must be standard diameter for the production block being used. Needle bearings will not be permitted.  
C. Camshafts must be driven in the same direction of rotation as that of the approved production engine.  
E. Hydraulic cam and hydraulic lifters must be used.

**20F – 5.8.2 VALVE LIFTERS ENGINE A&B -**

- A. Only magnetic steel hydraulic valve lifters will be permitted. Roller tappets, ceramic valve lifters, mushroom valve lifters and any type of mechanical assistance exerting a force to assist in closing the valve and/or push rod commonly known as rev-kits will not be permitted.  
B. Lifter must be operative and pass a leak-down test as well as removal and inspection.  
C. Valve lifters can weigh no less than **98 grams**.

**20F- 5.8.3 ROCKER ARMS ENGINE A&B** - Aluminum stud mounted roller rocker arms permitted. 7/16 studs may be used. Any steel pushrods. Chevrolet and Mopar must run 1.5 ratio rockers. Ford must run 1.7 ratio rockers. Chrysler may run adjustable rocker arm assembly from a 273 head on the 360 head. No stud-girdles. Stock type shaft rocker system is allowed on Chrysler only. No aftermarket shaft rocker systems.

**20F- 5.9 INTAKE MANIFOLD ENGINE A** - Stock cast iron passenger car manifolds of 2-barrel design only! Manifold must be one that was used with an OEM two-barrel carburetor. No throttle body manifolds allowed. Throttle bores can measure no more than 1.730" You are required to have an UNALTERED stock manifold. NO porting, polishing, acid dipping, deburring, de-flashing, abrasive cleaning, internal painting, milling, cutting, drilling holes, enlarging bolt holes, matching of ports or welding. Absolutely no modifications of any kind. A track supplied stock intake manifold must fit your engine complete with stock gaskets. All boltholes must be in alignment and same size as stock. Absolutely no coolant lines in the intake manifold, engine block, or sides of heads.

**20F- 5.9 INTAKE MANIFOLD ENGINE B** - **The only Intake manifold that will be allowed will be the second generation Edelbrock #2101. This intake must contain the made in the USA stamp.** You are required to have an UNALTERED manifold. No porting, polishing, acid dipping, deburring, de-flashing, abrasive cleaning, internal painting, milling, cutting, drilling holes, enlarging bolt holes, matching of ports or welding. Absolutely no modifications of any kind. A track supplied stock intake manifold must fit your engine complete with stock gaskets. All bolt holes must be in alignment and same size as stock. **Coolant lines are only approved from the water neck to the back side of heads.**

**NOTE: THAT STAFFORD SPEEDWAY RESERVES THE RIGHT TO SWAP OUT ANY COMPETITORS INTAKE MANIFOLD AS PART OF TECH INSPECTION**

- I. The maximum thickness allowed for the Intake gasket will be .064" no exceptions!

**20F- 5.10 CARBURETOR ALL ENGINES** -The only approved carburetor shall be the Holley two-barrel model # 4412. **ALL PARTS MUST BE A HOLLY PART FOR THE 4412.**

- (1) Body of Carburetor: No polishing, grinding or drilling of holes permitted.  
(2) The choke may be removed, but all screw holes must be permanently sealed.  
(3) Choke Horn: Choke horn may not be removed.  
(4) Boosters: Boosters may not be changed. Size or shape must no be altered. Height must remain standard.  
(5) Venturi: Venturi area must not be altered in any manner. Casting ring must not be removed.  
(6) Alterations to allow additional air to be picked up below the opening of the venturi such as altered gaskets, base plates and drilling holes into the carburetor will not be permitted.  
(7) Base Plate: Base plate must not be altered in shape or size.  
(8) Butterflies: Stock butterflies must not be thinned or tapered. Idle holes may be drilled in butterflies. Screw ends may be cut even with shaft but screw heads must remain standard.  
(9) Throttle Shaft: Shaft must remain standard and must not be thinned or cut in any manner.

**20F- 5.10.2 CARBURETOR SPACER ENGINE A** - Only one solid spacer made of aluminum or phenolic plastic of a maximum height of 1" permitted. Only one .075" max. gasket per side. No wedge shaped mounting surfaces, both top and bottom surfaces must be parallel. Spacer can be no larger than base of carburetor. Port holes or hole must be vertical to the surface with no beveling, tapering, or flaring. No additional openings for the induction of air allowed. All spacers must be approved by Track Officials.

**20F- 5.10.2 CARBURETOR SPACER ENGINE B – The only approved spacers for this motor will be the Canton #85-065 or the # 85-060 with a maximum height of 1" permitted. Only exception, .075" max. gasket per side. No additional openings for the induction of air will be permitted. All spacers must be approved by Track Officials.**

**20F- 5.12.1 CARBURETOR AIR FILTER / AIR FILTER HOUSING ALL**

- A. Only a round dry type paper air filter element maintaining a minimum 12 inches and maximum 14 inches diameter will be permitted. The air filter element must maintain a minimum of 1 ½" inches, maximum four (4) inches in height. All air must be filtered through the element.  
B. Only a round metal filter housing will be permitted. The top and bottom of the air filter housing must be solid with no holes. A maximum of one (1) inch lip will be permitted from the air filter element to the outer edge of the air filter housing top and bottom. The air filter housing carburetor mounting ring must have only one (1) round hole a minimum of five (5) inches in diameter. It is permissible to attach a shield to the front area of the air filter housing up to a maximum of one half of the air filter circumference. The shield must not be higher than the height of the air filter element. The air filter housing metal top and bottom must be of the same diameter. The air filter housing must be centered and set level on the carburetor. No air induction, ducts, baffles, tubes, funnels or anything else which may control the air entering inside of, or between the air filter and carburetor. No plastic air filter housings or parts.  
C. The bottom of the air filter element must measure within one (1) inch of the carburetor's top flange. A spacer may be used between the carburetor and the air cleaner so long as the one (1) inch specification is not exceeded.  
D. No part of the air filter or air filter housing will be permitted to protrude through the hood.

**20F - 5.12.2 AIR INTAKE ALL ENGINES**

- A. Only cowl air induction (cold air box) will be permitted. The only approved air box will be the five star C5 (cold air box) part #000-5224.**  
**B. Cars with hood scoops may have a centered opening, on the top of the rear of the hood scoop, measuring three (3) inches in length by 26 inches in width will be permitted through the top of the scoop. If competing with a hood without a hood scoop a cowl opening measuring three (3) inches by 26 inches will be permitted at the center of the cowl at the base of the windshield.**

C. A magnetic steel fabricated (cold air box) will be approved as long as it meets the exact dimensions, and appearance of part #000-5224. No exceptions!!

D. The only round dry type paper air filter element permitted will be 14 inches in diameter by three (3) inches in height. All air must be filtered through the element.



FIVE STAR Part # 000-5224



**20F- 6.1 IGNITION SYSTEM ALL - NASCAR APPROVED IGNITION SYSTEMS ONLY**

**A.** Electronic distributors are permitted. All electronic distributors must be in stock type housings, have stock type controls and modules, be equipped with a magnetic pickup, be gear driven, and be mounted in the stock location. Billet distributor housings are permitted

**B.** Single or dual point camshaft driven distributors are permitted.

**C.** Only one (1) ignition coil is permitted and must be mounted on engine side of the firewall.

**D.** Electronic firing module amplifier box is NOT permitted.

**E.** Computerized, multi-coil, dual electronic firing module box or crank trigger systems are not permitted. Magnetos are not permitted. All ignition systems are subject to approval by Track Officials.

**F.** Adjustable timing controls are not permitted.

**G.** Retard or ignition delay devices will not be permitted.

**H.** Only MSD # 8728 External RPM limiter with the violet wire cut back flush to the unit's housing, with the green and the white wires run directly to the coil negative, mounted on the engine side of the firewall in plane view, will be permitted (if used.)

**I.** Accessories to regulate the power supply are not permitted.

**J.** The tachometer wire must run from the distributor to the tachometer along the #8 dash bar separate from any other wires and in unobstructed view for inspection. The tachometer wire must be isolated from any other wires, connections or devices. The entire length of the tachometer wire must be visible from distributor to the gauge.

**K.** The Vacuum advance unit may be replaced with a manual non-electronic timing adjuster that does not extend more than two inches beyond the distributor housing.

**L.** The approved firing order using approved cylinder identification is as follows.

Dodge; 1-8-4-3-6-5-7-2

Ford; 1-3-7-2-6-5-4-8

G/M; 1-8-4-3-6-5-7-2

**M.** The manufactures cylinder identification sequence is as follows;

Dodge and G/M	Ford
Front	Front
1- 2	5-1
3-4	6-2
5-6	7-3
7-8	8-4

**N.** The Front engine cover material must be acceptable to NASCAR Officials.

**20F- 6.4 STARTER** - Stock type starter only. Must be in stock position and operative at all times.

**20F- 6.5 BATTERIES** – The battery must be located in an enclosed battery box, complete with a cover behind the front spindle but no further back than to have the front surface of the battery flush with the firewall or in front of the rear axle housing behind the rear firewall. The battery must be completely closed / sealed off on the drivers side of the firewall. The battery box must be mounted inside the outside edge of the frame rails and must not extend below the bottom of the frame rail. Any battery that would be installed during the race must be installed in the battery box. Only one (1) standard automotive 12-volt battery, not to exceed 13.5 volts, will be permitted. Accessories to regulate the power supply will not be permitted.

**20F- 6.7 ACCESSORIES** - No onboard computers, automated electronics, recording devises or digital readout gauges of any kind are permitted.

**20F- 6.7.1 RADIOS** – Radios are **MANDATORY** for communication between driver and crew. Stafford Speedway reserves the right to monitor and broadcast radio communications between the drivers and crews as well as the right to revoke any and all communication privileges of the driver and crew if at their sole discretion and judgment that communication is being misused in any way.

**NOTE:** Frequency listing available from: Master Frequency List.

**MASTER FREQUENCY LIST 1-207-934-0588.**

**20F- 6.7.2 SPOTTERS** – Spotters are **MANDATORY**. Every car must have a spotter monitoring race control by way of scanner or radio, located in front of race control with radio communication to their car unless otherwise directed by NASCAR Officials.

**20F- 6.7.3 TRANSPONDERS** – Transponder are required on the cars at all times. See Track Rules section for locating transponders properly. Any car not registering a transponder signal during practice will be black-flagged to be made aware of their scoring transponders failure and is required to remedy it before proceeding further in the event.

**MYLAPS AMERICA [www.mylaps.com](http://www.mylaps.com) 1-678-816-4000**

**20F- 7 ENGINE COOLING SYSTEM** - Only Water or Stafford Speedway Approved coolants or additives may be used in the cooling systems. The addition of coolant lines to the engine block or sides of the heads is not permitted.

#### **20F- 7.1 WATER PUMP**

A. Steel or aluminum OEM type only are permitted. Electric pumps are not permitted. Modifications of stock impellers are permitted. Combination water pump/alternator units are not permitted.

B. Any V-Belt or serpentine pulley and belt system is permitted. Cog belts or pulleys are not permitted. Pulleys may be either steel or aluminum.

**20F- 7.2 FAN** - Electric fans are permitted.

#### **20F- 7.4 RADIATOR**

A. Passenger steel or aluminum car radiators only. Radiators may be interchanged between makes and models but must be stock type. Radiator must be in stock location.

D. All cars must be equipped with an overflow catch-can located in the rear of the car behind the rear end and inside the frame rails. ***If the catch-can is place in the rear, the overflow line must not run inside the car!***

**20F- 8 ENGINE OIL SPECIFICATIONS** - The use of combustion enhancing oils or additives is not permitted.

#### **20F- 9 ENGINE EXHAUST SYSTEM ALL ENGINES**

A. Headers are permitted. Headers must be a commercially manufactured header using a 1 5/8" outside diameter steel primary tube. Maximum 30" in length, with a 3" outside diameter collector pipe. Primary tubes must exit down. Fender-well headers only are permitted. The header collector pipe cannot be reduced at any point between the primary tube and the exhaust pipe. Chevrolet must use one of the following or exact equivalent: Hedman #68600, Shonefield #185 or Dynateck #01-21900. Ford & Mopar must comply with all other specifications and be approved by Track Officials. Kooks stainless steel L/M Headers, P/N 15055, & **Flow Rite P/N FR250FF for stock snout and FR275FF for X-Y-G snout will** be allowed on all engine models.

B. Stepped and 180-degree headers are not permitted.

C. The exhaust header flange must mount directly to the cylinder head with no spacers between the flange and the cylinder head. A maximum header flange thickness of 1/2 inch is permitted.

D. Inserts are not permitted in any part of the header or collector. Merge, crossover and pyramid collectors are not permitted.

E. Exhaust pipes **must** be of 3" dia. exhaust tubing from header to muffler and from muffler to 12" behind the rear end. Tail pipes must have a minimum of a 45-degree downturn at the end if not exiting out the side of the car. Both exhaust pipes must be independent with no connection between them.

**F. Mufflers: - The three types of approved mufflers will be the LOBAK # RCM 30-12-30 or the R300-10 Kooks Stainless Steel, or Flow-Right P/N FR300 Stainless Steel mufflers are required at all times. Modifications or repairs of any type are not permitted on the muffler. Both Muffler flanges must be intact. Mufflers must be removable for inspection.**

**NOTE: It should be noted that the life expectancy for all Loback mufflers is two years. All owners are responsible to make sure their mufflers are in proper working order. If found not to be, the muffler will be deemed illegal (i.e. missing any of the internal construction.)**

G. Thermal wrap is not permitted anywhere on exhaust system.

H. Only one muffler and exhaust pipe allowed per side of the engine is permitted.

I. Exhaust system subject to approval by Track Officials.

J. Interior and exterior coatings are permitted.

### **SMS LATE MODEL SPEC ENGINE (ENGINE-C) REQUIREMENTS:**

***These SMS SPEC MOTOR rules are intended to create a standardized rule package to cut cost and increase the level of competition, If these rules are not followed as written, Stafford reserves the right to determine stiffer forms of penalties then we have in the past. THIS RULE IS STILL UNDER REVIEW BY STAFFORD SPEEDWAY!***

**20F- 4 GENERAL ENGINE REQUIREMENTS** - Engine must be OEM cast iron V8 production block, #10066034 or equal to no aftermarket or bow tie blocks. The only approved engine for GM is the CHEVROLET 350, the maximum decking of the block is 9.00". No angle milling of block deck. No offset dowel pins. No de-flashing, grinding, welding or painting of any internal area. Maximum overbore is .045". A max static compression ratio of 10.5 to 1 will be allowed.

**20F- 5 DETAILED ENGINE REQUIREMENTS** - ***All parts for this spec must maintain manufacturers overall dimensions and weight no exceptions! The approved part numbers are as follows:***

**GM BLOCK - #10066034**

**PISTONS- Wiseco Pro Tru -#PT003H JE SPR- #157076 Manley-#59053**

**Rods- Manley-14104-8 Crower Sports Rods- SP3205**

**Oil pan - MOROSO-#123412 Canton-11-122**

**Valves- Manley Intake #11596 & #11864 Manley Exhaust #11543 & #11863**

**Crank- Scat Cast or Steel - #9-350-3480-5700 & Callies Magnum Series**

**Intake- second generation Edelbrock #2101**

**Harmonic Balancers- ATI 917260 & 917320**

## **BHJ CH-IBF-6-C**

**(NOTE. THE ABOVE CAN BE REBUILT)**

**Carburetor Spacers CANTON- #85-060 & #85-065**

**Minimum ring thickness permitted is as follows:**

**Compression rings 1/16" Oil ring assembly 3/16"**

### **20F- 5.1 ENGINE LOCATION**

**A.** Engine must be in the stock location for a V8 in the chassis being run. Stock engine location is deemed to be when the distance between centerlines of the forward most fuel pump to engine block mounting bolt and the upper idler-arm to frame mounting bolt measures 8.75" inches +/- .25" inch so long as said bolts are deemed to be in stock, un-altered, factory locations.

**B.** The front, centerline of the crankshaft must be no less than 12 3/4" from the ground with the car's frame set on five (5") inch high blocks under all four outer corners of the frame.

### **20F- 5.5 PISTONS/RODS**

**A.** The approved piston part numbers are **Wiseco Pro Tru # PT003H, JE SPR #157076, and MANLEY #59053.** JE and Manley must maintain a 2.500" length pin only. Wiseco must maintain a 3.000" pin length. No gas porting of any type. All three rings must be working and of magnetic steel. No stainless, no z-gap, no gapless, **and no Dykes.** No portion of piston may protrude above the top of the block.

**The minimum ring thickness permitted is as follows:**

**Compression rings 1/16"**

**Oil ring assembly 3/16"**

**B.** Only magnetic steel non-coated piston pins maintaining a minimum diameter of .0927" inch are permitted. **They can only be contained by bushings only. (No bearings of any type) Full floating pins are permitted. No coating of wrist pins. (DLC, etc.)**

**C.** Piston pin holes must be in a fixed location in the piston and connecting rods.

**D.** Only two-piece insert style connecting rod bearings are permitted.

**E.** The Only solid magnetic steel stock type connecting rods that are permitted will be the **Manley # 14101-8** and the **Crower Sports Rod #SP3205.** Hollow beam connecting rods are not permitted. Only normal engine balancing and the use of after-market bolts and nuts are permitted. No de-burring, de-flashing, polishing, grinding or lightening. Billet connecting rods are not permitted. The only rod length permitted will be 5.700".

**F.** Titanium and stainless steel connecting rods are not permitted

**G.** Minimum weight for piston, pin, ring, bearing and rod assembly is **1185 grams.**

**20F-5.5.4 OIL PAN-** NO dry sumps, external oil pumps or tanks or accu-sump systems allowed. The only oil pans that will be permitted are the MOROSO #12312 and the Canton #11-122. Oil coolers are allowed. Only OEM in the pan magnetic steel type oil pumps are permitted. No pumps of any type may be used in the evacuation systems. **A one (1) inch inspection plug may be installed in the front of the pan, Moroso P/N MOR23970. This is to allow NASCAR Officials access to inspect connecting rods and crank shaft. This is optional but highly recommended.**

**20F-5.6.2 HEADS - CAST IRON.** The only CHEVROLET head allowed will be the DART casting part # 10024266, Angle plug, Bow-tie or Vortec heads are not permitted. Intake valve must be 2.02" only. Exhaust valve must be the 1.60" only. The head must have a minimum of 62cc combustion chambers. When heads are checked at the track you will be responsible for cleaning and carbon removal to make the respective cc limit. The only modifications ALLOWED will be the installation of valve guide sleeves and milling of the gasket surfaces. Milling of Exhaust flanges, angle milling, changing the angle of the head gasket surface in relationship to the rest of the head, altering the position or angle of the valve guide is not permitted. The addition of screw-in studs, guide plates, valve spring seats, optional valve seals, Poly-Locks or jam-nut devices are permitted. The only machining of valve guide bosses allowed, is for seals only. Coolant return lines are allowed to be placed on the ends of the heads. No lines will be allowed on the sides of the head. Other head modifications that are not permitted include but are not limited to: Porting, polishing, Any grinding in ports or combustion chambers, chemical milling, glass beading or removal of any flashing or casting marks. No welding or sectioning. No internal modifications of any kind including painting or Teflon coating. No more than two intake-mounting holes may have HeliCoils. Intake or exhaust manifold mounting holes may not be added or relocated. Holes must take standard intake manifold bolts. All external dimensions must remain.

**A.** All heads will be subject to max port volumes. Max Intake volume will be **177cc.** The max Exhaust port volume will be **71cc.** The Intake to pin measurement must be no less than 6.050" no exceptions!

**VALVES -** The only valves that are permitted will be the **Manley valves, Intake # 11596 @ 111 grams, Intake #11864 @ 114 grams, Exhaust #11543 @ 95 grams, and Exhaust valve # 11863 @ 102 grams.** No air directional devices will be permitted on any of the valve surfaces. Valve stems must have a minimum diameter of 11/32 inch. Valve lifters can weigh no less than **85 grams.** All parts must maintain production gram.

**VALVE JOB -** When cutting the valve seat angles, no stone or grinding marks are permitted above the bottom of the valve guide. All cutting in reference to the valve job must be centered off the centerline of the valve guide. Upon completion of the valve job, the bowl area under the valve seat down to the bottom of the valve guide should still be the same configuration as far as shape and finish as it was from the manufacturer. **The bowl area must pass the "ball" check. Intake must pass a .787" ball. The exhaust must pass a .531" ball.** Surfaces and/or edges where the cutter or stone has touched must not be polished. No hand grinding or polishing is permitted on any part of the head.

**VALVE SPRINGS & RETAINERS -** The only steel retainers allowed will be of a weight no lighter than 30 grams. No barrel wound, conical wound springs, or beehive type springs will be allowed. ALL windings must be parallel. Valve spring retainers must be OEM steel or stock or stock replacement steel only. Double valve springs with a max diameter of 1.450" and a minimum diameter of 1.437" will be allowed. Valve springs must have a height of 1.750" min to 1.800" max. No lightweight retainers will be allowed. The only locks that will be allowed will be the Machine 7degree Super 7degree, and the 10 degree magnetic steel only!

### **20F- 5.7 CRANKSHAFT**

**A.** The only allowed Crankshafts will be the **Scat Cast or Steel Crank # 9-350-3480-5700** and the **Callies Comp Star series.** The main and rod journal sizes are .020" under for the main and .030" under for the Rod journals. The only stroke will be the 3.480".

**B.** Small journal, or Honda pin crankshafts will NOT be permitted.

**C.** NO machining or polishing of the crankshaft counterweights allowed. NORMAL engine balancing will be the ONLY acceptable modification that can be performed on this component. No painting or Teflon coating. No capping of the counterweight holes. Crankshafts must maintain the manufacturers appearance.

**D.** Minimum crankshaft weight will be **47lbs.**

E. The Only OEM magnetic steel elastomer type harmonic balancers will be the **Power Bond #pb1012-ss , ATI 917260 , 917320, and the BHJ CH-IBF-6-C only.**

**20E- 5.8.1 CAMSHAFT** - Only magnetic steel camshafts will be permitted. The maximum camshaft bearing journal size must not be more than **1.875" (475mm)**. Camshaft must not exceed .550 lift at the valve with zero lash.

A. Any type chain will be permitted. Belt-drive and gear-drive systems will not be permitted.

B. Only production sleeve type bearings will be permitted and must be standard diameter for the production block being used. Needle bearings will not be permitted.

C. Camshafts must be driven in the same direction of rotation as that of the approved production engine.

E. Solid cam and lifters may be used.

#### **20F – 5.8.2 VALVE LIFTERS**

A .842" diameter magnetic solid steel valve lifter will be the only diameter permitted. Roller tappets, ceramic valve lifters, mushroom valve lifters and any type of mechanical assistance exerting a force to assist in closing the valve and/or push-rod commonly known as rev-kits will not be permitted.

B. Valve lifters can weigh no less than **85 grams**.

**20F- 5.8.3 ROCKER ARMS** - Aluminum or stainless stud mounted roller rocker arms are permitted. 7/16" studs may be used. Steel 5/16" x .080" wall push rods must be used. Chevrolet must run 1.5 ratio rockers. No stud-girdles. No aftermarket shaft rocker systems.

**20F- 5.9 INTAKE MANIFOLD** - **The only Intake manifold that will be allowed will be the second generation Edelbrock #2101. This intake must contain the made in the USA stamp.** You are required to have an UNALTERED manifold. No porting, polishing, acid dipping, deburring, de-flashing, abrasive cleaning, internal painting, milling, cutting, drilling holes, enlarging bolt holes, matching of ports or welding. Absolutely no modifications of any kind. A track supplied stock intake manifold must fit your engine complete with stock gaskets. All bolt holes must be in alignment and same size as stock. **Coolant lines are only approved from the water neck to the back side of heads.**  
**NOTE: THAT STAFFORD SPEEDWAY RESERVES THE RIGHT TO SWAP OUT ANY COMPETITORS INTAKE MANIFOLD AS PART OF TECH INSPECTION**

I. The maximum thickness aloud for the Intake gasket will be .064" no exceptions!

**20F- 5.10.2 CARBURETOR SPACER** - The approved spacers for this motor will be the Canton # 85-065 , # 85-060 , **#85-060s or the #85-065s** with a maximum height of 1" permitted. Only exception, .075" max. gasket per side. The port holes of these spacers can be modified as long as it does not exceed a width of 1.730" and a length of 3.600" with each end maintaining the manufacturer's radius. No additional openings for the induction of air will be permitted. All spacers must be approved by Track Officials.

**20E- 15 FUEL SPECIFICATIONS** - The only approved fuel will be SUNOCO 260 GTX no exceptions!

A. Icing or cooling of the fuel system is not permitted in the garage, pit or racing area.

B. Gasoline may be tested and certified at any event through the application of various chemical analyses as considered appropriate by officials. Gasoline may be checked before, during and after the racing events.

C. Nothing may be placed in the fuel line other than a standard fuel filter. The use of any type of fuel catalyst or other fuel-altering devices is prohibited.

**The only approved labor will be as follows:**

**Bore & hone block w/plates .045" over.**

**Cut flats of block.**

**Deck block 9.00" max.**

**Prep block**

**line hone block**

**Boil cam bearings and plugs**

**Balance engine /normal no capping of holes**

**Fit 8 rods and side clearance**

**Hang 8 pistons and pin fit**

**Clean and polish crank shaft**

**Touch seats on new heads**

**Cut 4 sides of new heads/NO ANGLE MILLING**

**cutting for valve seals & spring pockets will be permitted**

**Fit 16 guides**

**No other labor will be allowed.**

**The only procedure that will be grand fathered in at this point & time will be SLEEVES FOR THE LIFTER BORES in the old blocks. IF USING A NEW BLOCK AND YOU WANT TO INSTALL LIFTER BORES, IT WILL INCREASE THE TOTAL COST BY A FEW HUNDRED DOLLARS.**

## **STAFFORD MOTOR SPEEDWAY**

### **LATE MODEL**

### **SPEC ENGINE PARTS PRICE LIST BREAKDOWN**

(All prices are taken from 3 different warehouse suppliers)

(PARTS IN THIS SECTION ARE ALL **MANLEY PARTS**)

<i>VALVES - SEVERE DUTY - INTAKE - #11596</i>	<i>\$23.95 ea = \$191.16 set of 8</i>
<i>EX - #11543</i>	<i>\$23.95 ea = \$191.16 set of 8</i>
<i>RACE MASTER - INTAKE - #11864</i>	<i>\$15.76 ea = \$126.08 set of 8</i>
<i>EX- #11863</i>	<i>\$15.76 ea = \$126.08 set of 8</i>
<i>PISTONS - PLATINUM SERIES - #590530</i>	<i>\$559.95 set</i>
<i>RINGS - #46353</i>	<i>\$144.00 set</i>
<i>RODS - #14101</i>	<i>\$627.00 set</i>
<i>CAM BUTTON</i>	<i>\$7.00</i>
<i>CAM LOCK PLATE &amp; BOLT KIT</i>	<i>\$5.00</i>
<i>VALVE SPRINGS - #22408</i>	<i>\$159.00 set</i>
<i>#22407</i>	<i>\$159.00 set</i>
<i>RETAINERS - 7 DEG - #23645</i>	<i>\$50.72 set</i>
<i>10 DEG - #23635</i>	<i>\$50.72 set</i>
<i>LOCKS - 7 DEG - #13090</i>	<i>\$64.39 set</i>
<i>10 DEG - #13194</i>	<i>\$45.00 set</i>
<i>SUPER 7 - #13083</i>	<i>\$60.69 set</i>
<i>SPRING LOCATORS - #42126</i>	<i>\$61.95 set</i>
<i>GUIDE PLATES - #42355</i>	<i>\$21.95 set</i>
<i>VALVE STEM SEALS - #24035</i>	<i>\$19.95 set</i>
<i>#24037</i>	<i>\$19.95 set</i>
<i>PUSH RODS - 5/16 .080 wall</i>	<i>\$7.95 ea = \$127.20 set of 16</i>
<i>ROCKER STUDS - #42277</i>	<i>\$55.39 set</i>
<i>BOLTS</i>	
<i>MAIN - # ???</i>	<i>\$36.76 set</i>

HEAD - #42171	<b>\$33.95 set</b>
WASHERS - #42127	<b>\$13.95 set</b>
TIMING COVER - #42174	<b>\$10.53 set</b>
OIL PAN - #42173	<b>\$11.69 set</b>
BALANCER BOLTS - #42223	<b>\$32.00 ea</b>
STUDS	
MAIN - # ???	<b>\$66.76</b>
HEADS - #42190	<b>\$122.00 set</b>
TIMING COVER - #42134	<b>\$29.80 set</b>
OIL PAN - #42148	<b>\$64.00 set</b>
TIMING CHAINS - #73181	<b>\$109.95</b>
#73161	<b>\$104.39</b>
OIL PUMPS - #71089	<b>\$80.60</b>
OIL PUMP STUD & DRIVE SHAFT - #42339	<b>\$5.50 ea</b>
#42328	<b>\$13.95 ea</b>
FUEL PUMP PUSH ROD - #42236	<b>\$20.00 ea</b>
OIL RESTRICTOR KIT - #42237	<b>\$5.00 ea</b>
LIFTER VALLEY - BREATHER TUBES - #42235	<b>\$23.60 ea</b>

Price (with Race master valves, Super 7 locks and Bolts) = **\$2,528.24**

Price (with Severe Duty valves, 7 deg locks and studs) = **\$2,826.98**

**(ALL OTHER PARTS NEEDED)**

<u>GM ENGINE BLOCK # 10066034</u>	<b>\$832.82 NEW / \$200.00 USED</b>
2 Dart Cylinder heads- # 10024266	<b>\$540.00</b>
Crank - SCAT / Cast	<b>\$229.29</b>
Crank - SCAT / Steel #4-350-3480-5700	<b>\$429.99</b>
Callies /Steel	<b>\$620.00</b>
Intake Manifold - Edelbrock - #2101	<b>\$150.00</b>

<i>Bearings</i>	
<i>Clevite 77 Main</i>	<i>\$58.95</i>
<i>Rod</i>	<i>\$57.95</i>
<i>Cam</i>	<i>\$19.00</i>
<i>Lifter/ bushings</i>	<i>\$80.00</i>
<i>Set of brass freeze plugs</i>	<i>\$8.00</i>
<i>Bolts</i>	
<i>ARP Engine kit accessories bolts (Includes all bolts for all external parts)</i>	<i>\$50.00</i>
<i>Studs</i>	
<i>Valve Cover - #2007601</i>	<i>\$14.00</i>
<i>Carburetor - #200-2402</i>	<i>\$13.95</i>
<i>Balancers Pro Product #90010</i>	<i>\$197.00</i>
<i>ATI</i>	<i>\$445.00 (RE-BUILDIBLE)</i>
<i>Timing cover</i>	<i>\$30.00 to \$59.00</i>
<i>Aluminum valve covers</i>	<i>\$112.00 to \$125.00</i>
<i>Filler Cap</i>	<i>\$20.00</i>
<i>1 or 2 Edelbrock breathers</i>	<i>\$25.00 per breather</i>
<i>Oil Pan</i>	
<i>Moroso #21312</i>	<i>\$299.00</i>
<i>Canton #11-122</i>	<i>\$318.00</i>
<i>Moroso Oil Pump Pick Up Tube</i>	<i>\$45.00</i>
<i>Moroso Debris Screen Kit</i>	<i>\$17.00</i>
<i>Moroso vally splash tray</i>	<i>\$34.00</i>
<i>Moroso magnet kit</i>	<i>\$15.00</i>
<i>Gaskets (An average price from CARQUEST, Mr. Gasket, &amp; Fell-Pro)</i>	

<i>Valve Cover</i>	<b>\$30.00</b>
<i>Oil Pan</i>	<b>\$12.75</b>
<i>Head</i>	<b>\$134.00</b>
<i>Intake</i>	<b>\$15.00</b>
<i>Gasket set- Fuel Pump, Header, Water Pump, Distributor, Water Neck, &amp; Timing-Cover</i>	<b>\$20.00</b>
<i>1.5 Rocker arms</i>	<b>\$145.00 to \$445.00</b>
<i>Carb Adapter</i>	<b>\$50.00</b>
<i>Camshafts (average from three Cam Co.'s)</i>	<b>\$169.00 to \$250.00</b>
<i>Lifters</i>	<b>\$98.00 to \$160.00 a set</b>
<i>Oil Filter</i>	<b>\$14.00</b>
<i>Set of Spark Plugs</i>	<b>\$20.00</b>
<i>Assembly Lube</i>	<b>\$5.00</b>
<i>One Tube of Silicone Sealer</i>	<b>\$4.00</b>
<i>Break-In Oil</i>	<b>\$40.00</b>
<i>OTHER AVAILABLE PARTS</i>	
<b><i>BALANCER -BHJ</i></b>	<b>\$380.00</b>
<b><i>PISTIONS -WISECO PRO TRU #PT003H</i></b>	<b>\$563.00</b>
<i>RODS- CROWER SPORTS ROD #SP3205</i>	<b>\$626.77</b>
<i>RODS- SCAT RODS #SCT-25700</i>	<b>\$259.99</b>

**TOTAL: \$6134.93 to \$7409.67 (These prices are with new block & one with a Cast crank, & one with a Steel Crank. ) There will be another savings of \$532.00 buy using a pre-used block. There are also many other parts that can be used from current motors, engines. ( Heads,oil pans,pistons & rods etc.)**

**THE ONLY APPROVED LABOR FOR LATE MODEL**

***NO OTHER LABOR WILL BE ALLOWED!!***

- 1. BORE & HONE BLOCK W/PLATES .045 OVER***
- 2. CUT FLATS OF BLOCK***
- 3. DECK BLOCK 9.000 MAX***
- 4. PREP BLOCK***
- 5. LINE HONE BLOCK***
- 6. BOIL CAM BEARINGS AND PLUGS***
- 7. BALANCE ENGINE/NORMAL NO CAPPING OF HOLES***
- 8. FIT 8 RODS AND SIDE CLEARANCE***
- 9. HANG 8 PISTONS AND PIN FIT***
- 10. CLEAN AND POLISH CRANK SHAFT***
- 11. TOUCH SEATS ON NEW HEADS***
- 12. CUT 4 SIDES OF NEW HEADS/NO ANGLE MILLING***
- 13. FIT 16 GUIDES***

THIS PROGRAM WAS DEVELOPED TO SAVE ON REBUILD COST, (THESE ENGINES WILL ONLY NEED TO BE REFRESHED ONE TIME A YEAR) FOR BOTH DIVISIONS!!

***NOTE: THIS IS FOR SPEC ENGINE ONLY !***

**This program was designed to promote a better technical atmosphere by involving the engine builders in the process of technical inspection. This will help keep the full integrity of the Spec Engine program intact. Any published engine builder whose engine finishes in the top three will be involved in the tech process.\***

***\* Until the program is fully in place. If there is not more than one spec engine builder, the Tech Official will pick an alternate builder to be part of the process.***

## ENGINE BUILDER LIST AND QUOTES

✓ *BREAK IN DYNO TIME INCLUDED*

✓ *AT TRACK SUPPORT*

*(TAX NOT INCLUDED IN PRICE QUOTES)*

IF YOU WOULD LIKE TO BE ADDED TO THE LIST OR HAVE ANY QUESTIONS, CALL STAFFORD SPEEDWAY R & D AT (413) 786-2926 OR CALL THE STAFFORD SPEEDWAY OFFICE AT (860) 684-2783.

<p><b>DON WOOD</b> 80 RAVENWOOD DR. LUDLOW, MA 01056</p>	<p><b>RaD AUTO MACHINE</b>  (413)-583-4414</p>	<p>SK - \$11,800 ✓ ✓ LM - \$9,300 TO \$9,800 ✓ ✓ DEPENDING ON CRANKSHAFT</p>
<p><b>TONY ALTERI</b> 124 HILL TOP ROAD PLANVILLE, CT 06062</p>	<p><b>T/A ENGINES</b>  (860)-747-6713</p>	<p>SK - \$11,800 ✓ ✓ LM - \$9,300 TO \$9,800 ✓ ✓ DEPENDING ON CRANKSHAFT</p>
<p><b>BILL MATHES</b> 79 HAYES STREET TORRINGTON, CT 06790</p>	<p><b>PERFORMANCE ENGINES</b>  BY BILLY THE KID (860)-489-0363</p>	<p>SK - \$12,000 ✓ ✓ LM - \$11,000 ✓ ✓</p>
<p><b>LES LUGINBUHL</b> 3A COURTNEY DRIVE ELLINGTON, CT 06029 EMAIL: HorsePowerEngineering@yahoo.com</p>	<p><b>HORSEPOWER ENGINEERING</b>  (860)-871-2020</p>	<p>SK - \$9,250 TO \$11,250 ✓ DEPENDING ON UPGRADES LM - \$9,300 TO \$9,800 ✓ DEPENDING ON CRANKSHAFT</p>
<p><b>MIKE PETTIT</b> 44 OLD STATE ROAD UNIT 38 NEW MILFORD, CT 06776</p>	<p><b>PETTIT RACING ENGINES</b>  (860)-354-3339</p>	<p>SK - \$X,XXX LM - \$X,XXX</p>
<p><b>GARY ESPINOSA</b> 30 TAUGWONK SPUR RD. STONINGTON, CT 06378</p>	<p><b>LARRY'S AUTO MACHINE</b>  (860)-535-3173</p>	<p>SK - \$X,XXX LM - \$X,XXX</p>

<i>BILL CARLQUIST</i>	<i>CARLQUIST COMPETITION</i>	<i>SK - \$12,050</i>	✓	✓
<i>98 FALLS AV.</i>	<i>ENGINES</i>	<i>LM - \$10,050</i>	✓	✓
<i>OAKVILLE, CT 06779</i>	<i>(860)- 247-0742</i>			
<i>PETER CHILLEMI</i>	<i>EAST COAST MACHINE</i>	<i>SK - \$X,XXX</i>	✓	
<i>59 OLD BROADWAY</i>	<i>(203)-996-8767</i>	<i>LM - \$X,XXX</i>	✓	
<i>NORTH HAVEN, CT 06473</i>				
<i>E-MAIL: EastCoastMachine@yahoo.com</i>				
<i>DAVE MILLER</i>	<i>AUTOMACHINE LLC.</i>	<i>SK - \$X,XXX</i>		
<i>55 NEWBERRY ROAD</i>	<i>(860) 627-9244</i>	<i>LM - \$X,XXX</i>		
<i>EAST WINDSOR, CT 06088</i>				
<b><u>ANDY KRAWIEC</u></b>	<b><u>ANDY'S AUTO</u></b>	<i>SK - \$12,050</i>	✓	✓
<b><u>MACHINE</u></b>		<i>LM - \$9,800</i>	✓	✓
<i>48 LEWIS STREET</i>	<i>(860)-793-2455</i>			
<b><u>PLAINVILLE, CT 06062</u></b>				
<i>E-MAIL: andrewkrawiec@snet.net</i>				
<i>NORM CASE</i>	<i>PRECISION AUTOMOTIVE</i>	<i>SK - \$X,XXX</i>		
<i>9 HERMAN DRIVE</i>	<i>(860)-651-3418</i>	<i>LM - \$X,XXX</i>		
<i>SIMSBURY, CT 06070</i>				
<i>BRIAN KOWALYSHYN</i>	<i>SPECIALTY PERFORMANCE</i>	<i>SK - \$9,500</i>	✓	
<i>160 OLIVER ROAD</i>	<i>ENGINES</i>	<i>LM - \$8,500 TO 9,000</i>		✓
<i>LEBANON, CT 06249</i>	<i>(860)-642-9050</i>			
<i>EMAIL: specialtyperformanceengines@hotmail.com</i>				
<i>BOB LECCE</i>	<i>ROBICO RACING ENGINES</i>	<i>SK - \$X,XXX</i>		✓
<i>537 OLD COLCHESTER ROAD</i>	<i>(860)-859-0804</i>	<i>LM - \$X,XXX TO X,XXX</i>		✓
<i>SALEM, CT 06420</i>				
<i>EMAIL: rclecce@yahoo.com</i>				

flywheel of OEM stock dimensions may be used. OEM type steel pressure plate and steel disc only. Solid type disc only, no paddle or button type discs. Minimum 10" clutch and pressure plate. Drilling or lightening of any part is not permitted. Steel bolts only. Flat surface machining allowed only on the face of the flywheel, any cutting on the back side of the flywheel will deem the part illegal.

The following weights are the minimum allowed for each part:

Flywheel only (no bolts)

Non-Spec - 12.5 lbs.

Spec Motor - 9 lbs.

Pressure plate, Cover, & Solid Disc (no bolts) - 16 LBS.

The steel solid disc (no bolts) must maintain a minimum weight of 2.5 pounds and a maximum weight of 3.8 pounds after the combined weight has been determined.

**For Spec Engines only, available from 10,000RPM is a flywheel part number SMS10, and part number SMS10-3 for a full clutch assembly.**

**20F- 10.3 BELL HOUSING** – Only a special production all magnetic steel bell housing can be used. The bell housing must enclose the flywheel 360 degrees with minimum ¼ inch magnetic steel. Any changes to the bell housing must be made with ¼ inch magnetic steel and welded in place. All welds must be done inside and outside of the bell housing. No bolt on pieces. An opening no larger than 3 ½ x 4 inches may be used for throw out bearing access. This hole may be covered with sheet metal.

#### **20F- 10.4 TRANSMISSION**

A. Only OEM production stock 3 & 4 speed transmissions may be used. Top loader transmissions are not permitted. **Gear ratio must be of stock OEM production.**

**B. Only stock O.E.M. factory housings will be permitted.**

C. Only OEM type, steel, angle cut forward gears are permitted. Square cut forward gears are not permitted.

D. Removal of first gear, or replacement of first gear with a metal spacer, in 4-speed transmissions is permitted. All other forward and reverse gears must be in working order, and they must be operational from inside the driver's compartment. All transmissions must have a constant engagement of the input shaft with gear and countershaft with cluster gears.

E. Five-speed transmission, with gears removed are not permitted.

F. Quick change transmissions are not permitted.

G. Automatic or semi-automatic transmissions are not permitted.

H. Machining or lightening of any internal rotating or non-rotating parts including gears, shafts and case is not permitted. Gun drilled transmission shafts are not permitted. **Welding on any internal part will not be permitted.**

I. Additional or different from OEM bearings other than the tail-shaft, which may have roller bearings, are not permitted.

J. Auxiliary, over or under drive transmissions are not permitted. High gear must have a ratio of 1 to 1 and no other gear may have a ratio higher than 1.20 to 1.

#### **20F- 10.5 DRIVESHAFT**

A. The drive shaft, universal joints, and yoke must be magnetic steel and be similar in design to the standard production type. The drive shaft must be made of one-piece magnetic steel and must either 2-3/4 inches or 3 inches in diameter.

B. Two (2) 360 degree solid magnetic steel brackets with no holes or slots, not less than two (2) inches wide and ¼ inch thick, must be placed around the drive shaft. The front bracket must be welded to the rear suspension cross-member and the rear bracket must be welded or bolted, with a minimum of two 3/8 inch diameter bolts on each side, to the horizontal tunnel bar (#6).

C. All drive shafts must be painted white.

**20F- 10.6 REAR AXLE** - The rear axle must meet the following requirements: Rears may be changed between different makes and models. If a FORD rear is used in a GM chassis, the rear drums may be drilled for the GM bolt pattern.

A. The center of the rear end housing must be within 1" of the centerline of the track width, front and rear.

B. Differential gears must be welded or replaced with a steel spool. No posi-traction, limited-slip or ratchet differentials allowed.

C. Only one-piece, magnetic steel rear end axle housings will be permitted.

D. Racing axles are mandatory on both sides for all General Motors rears. Full floating double splined rear axles may be used. Only solid magnetic steel axles allowed. Hollow or drilled axles will not be permitted. Full floating double splined rear axle minimum weight is 9.0 lbs.

E. Only magnetic steel axels, drive plates, bearings, and axle housings are allowed. No aluminum parts allowed in or on the rear axle assembly except for the axle caps *and brackets for third link*.

F. Cambered rear axle housings will not be permitted. The method used to check camber will be the NASCAR Officials' option.

G. Only magnetic steel drive plates, the same thickness on the left and right side, will be permitted. The drive plates must be one-piece with a single straight cut internal spline. Grease fittings are permitted on drive plates and axle caps.

H. Upper trailing arms may be replaced with steel arms with heim joints or rubber mounts. A steel panhard bar or 'watts link' may be used. Heim joints or rubber mounts are permitted. Upper arm must be a maximum of 13 inches from the vertical centerline of the rear axle to the centerline of the forward mounting point. No shocks.

I. Stock, or D.C.A lower trailing arms P/N 17812, JCI-03-01M&B, or JCI-03-02-M&B are permitted. Stock lower trailing arms may be plated for added strength, which will make them equal to the D.C.A. replacements. Lower trailing arms for the chassis used, must attach to the frame in the stock location. Mounting brackets on the axle tubes may be moved but rear axle housing must be centered in chassis. Left and right backing plates must be an equal distance from the frame rails.

J. Springs must be mounted on axle housing in stock location for frame being used.

**20F- 10.6.1 REAR GEAR** – The rear ring and pinion gears must be stock type. The ring gear must weigh a minimum of 12 lbs. The spool with 2 bearings only (less bearing cups) must weigh a minimum of **7.0lbs.**

**GEAR RULE:** 4:86 to 1 MINIMUM, 5:14 to 1 MAXIMUM.

**20F- 10.7 WHEELS** - Racing or wagon wheels are mandatory. Maximum wheel width is eight (8) inches. The offset of all four wheels must measure the same (+ or - 1/4"). No part of any tire may be outside of the body. No magnesium or aluminum wheels.

**20F- 10.8 TIRES** - All tires must be purchased from the track tire dealer. The only tires permitted are the American Racer P225/70-15 treaded DOT tire in 704 compounds on the left side and 705 compounds on the right side. The JTR Eagle PPM Tester will be set at a fixed level and will be strictly enforced throughout the 2009 season

## 20F- 10.8.1 PHYSICAL REQUIREMENTS

F. Minimum Tire Pressures for all inspection purposes are *ten (10) psi for both left side tires and fifteen (15) psi for both right side tires*. Air may be added to the tires to achieve only the minimum tire pressures during inspections, per a track provided tire pressure gauge.

**NOTICE: A participant competing in any race at Stafford Motor Speedway, specifically agrees that he/she acknowledges that it is illegal to soak or treat racing tires and that said soaking or treatment of racing tires is against EPA regulations and further contains carcinogens and hazardous material which are unfit for his/her health and the health of all competitors and spectators. Any participant found violating the rule will be subject to suspension.**

**20F- 11 FRAMES** - All frames must be stock for year make and model. Front and rear spring pockets may be altered for stacking bolts. No plating or reinforcing of the frame in any way beyond or outside of the following specifications. Unibody cars are not permitted.

A. The front frame horns may be replaced with 2" X 3" .083" square tubing from the forward most 1/2" measuring hole to the front bumper. No other part of front frame rails can be replaced with tubing.

B. The front cross member must remain stock. The raised portion of the front cross member may be replaced with steel flat stock welded in flush with the rest of the cross member, maintaining a minimum two inch (2") thickness of the stock cross member for oil pan clearance only.

C. Rear frame rails may be replaced with 2" x 3" .083" magnetic steel square tubing from the rear edge of stock upper crossmember back, only if following stock configuration height, width, and length. Optionally the replacement rear frame rails may extend parallel rearward maintaining a minimum width of the stock frame rails width at rear most edge of the upper crossmember. The upper crossmember may be removed.

D. No offset or shortening of frame rails.

E. Frames must measure within a 1/4inch of all factory specifications for year, make, and model used. All measuring cups or holes must remain unaltered.

F. Tubing of a size and length that will not protrude from the stock frame may be located inside the driver's side frame rail. All roll cage bars normally attaching to the drivers side frame rail must be welded directly to the supplemental tubing.

G. Tubing may be utilized as a replacement for the stock transmission crossmember. Any non-stock replacement transmission crossmember must be located perpendicular at 90 degrees to the stock frame rails and no further towards the rear of the car than to have the rear edge of the tubing even with the rear edge of the transmission hosing.

H. Additional X-tubing may be added so long as the tubing connects to the crossmember and is NOT one continuous piece running from corner to corner of the stock frame. The X-tubing must attach within the two corners of each frame turnout. The X-tubing can NOT extend past any of the frame turnouts and must not be attached to the perimeter frame rails short of the frame turnouts.

**FORD FRAMES** - Ford full-size frames, (LTD, Crown Victoria) 1979 and newer may be shortened to 108" wheelbase. Frame must be shortened in center section only using the same area on both sides.

## 20F – 11.2 OPTIONAL Tubular Mandrel bent Front Sub-Frame

C. The front sub-frame must be constructed by the following guidelines:

### **ALL VERTICAL DIMENSIONS WILL BE ON FIVE (5) INCH RIDE HEIGHT BLOCKS**

Many Dimensions will come from a front frame kick-out that is eighty six (86) inches from the rear axle centerline constructed of three (3) inches wide by four (4) inches magnetic steel tubing with a minimum wall thickness of 0.125 inch meeting ASTM A-500 specifications. The GM-METRIC TUBULAR mainframe width will be an O.E.M. dimension of fifty four (54) inches from the outside of the left frame rail to the outside of the right frame rail and a length of sixty six (66) inches starting at a point eighty six (86) inches forward from the rear axle centerline constructed using three (3) inch wide by four (4) inch high magnetic steel tubing with a minimum wall thickness of 0.125 inches.

(1) A GM-METRIC type front steer tubular front sub-frame must be constructed using two (2) inch wide by four (4) inch high magnetic steel tubing with a wall thickness of 0.125-inch meeting ASTM A-500 specifications. The front sub-frame rails must be parallel to each other both vertically and horizontally. The front sub-frame rails must be parallel both vertically and horizontally to the mainframe rails from the jack bolts forward. All front steer assemblies must maintain a dimension of 31 inches from the center of the left side frame rail to the center of the right side frame rail at a point from the jackbolt extending forward in front of the steering assemblies. Spring bucket and jack bolts may be cut into left side and right side frame rails. Top of spring buckets will maintain a vertical height of 15 1/4 (+/-) 1/2 inch. Jack bolts will maintain a centerline distance of 33 1/2 (+/-) 1/2 inch measured at top of spring bucket from left side to right side and be located equal distance from centerline left and right. A distance of 21 inches (+/-) 1/4 inch must be maintained from the front frame kick-outs forward to the jack bolts centerline. Jack bolts will be allowed a maximum angle of five (5) degrees from vertical. The front sub frame rails may angle outwards and downwards from the jack bolts to the front frame kick-out to a maximum distance of 41 inches. If frame rails are angled outward a wishbone made from round magnetic steel seamless tubing 1 1/2 inch by .083 minimum wall thickness meeting ASTM A-519 specification must extend from dash bar #8 to an area at the rear lower a-frame mount and continue to connect at an intersection of roof support bar #12 and diagonal bar # 7A. The front frame extensions using two (2) inch wide by three (3) inch high minimum wall thickness of 0.083 inch magnetic steel tubing meeting ASTM A-500 specifications must angle out and forward and extend a distance of twelve (12) inches forward of the forward most top steering box bolt to a minimum distance of 33 inches from the center of the left side frame rail extension to the center of the right side frame extension. This forward top steering box bolt will be a horizontal distance of 39 inches from the front frame kick-out and a vertical height of 15 inches (+/-) 1/2 inch. (steering box bolt location will be inspected with a fixture that will read zero (0) degrees with the frame on five (5) inch ride height blocks) At a point four (4) inches in front of the top steering box bolt a two (2) inch wide by four (4) inch high magnetic steel tubing with a minimum wall thickness of 0.125 inch meeting ASTM A-500 specification must extend rearward a distance of 34 inches than angle down 30 degrees to the front frame kick-out. A distance of 24 1/2 (+/-) 1/8 inch must be maintained to the center of an O.E.M. three quarter (3/4) inch pin boss located on the mainframe centerline at the front of the front sub-frame crossmember. O.E.M. pin boss will be used for locating inspection fixtures. The front sub-frame crossmember must be mounted at the centerline of the front sub-frame at a 90 degree angle against the back of the 3/4 inch pin boss and be constructed using two (2) inch high by four (4) inch wide magnetic steel tubing with a minimum wall thickness of 0.125 inches meeting the ASTM A-500 specifications. A minimum thickness of one hundred thousandths (0.100) 12ga. magnetic steel must be used to construct the remainder of the front sub-frame crossmember. The front mounting points for the front lower a-frames must be constructed using a minimum 3/16 inch thickness magnetic steel. The front mounting points for the front lower A-frames must be 9 3/8 inches, measured from the centerline of the front sub-frame to the centerline of the mounting bolt at the front side of the mount and a vertical height of seven (7) inches (+/-) 1/4 inch. The rear mounting points for the lower A-frames must be constructed using a minimum 3/16 inch thickness magnetic steel. The rear mounting points for the lower A-frame must be 13 inches (+/-) 1/4 inch measured from the centerline of the front sub-frame to the centerline of the mounting bolt at the rear side of the mount and the vertical height will be 6 7/8 inches (+/-) 1/4 inch. Adjustable insert slugs may be used on the rear mounting bolt to maintain a distance of 22 inches (+/-) 1/2 inch from the center of the lower ball joint to the leading edge of the mainframe side rail and kick-out. A 1/2 inch round by 15 inch long solid steel pin must pass freely through these points during inspection. When measuring either the right side or left side the distance from the centerline of the bottom ball joint to the centerline of the sub-frame must be equal. The mounting plates for the upper A-frames must be welded to the top of the sub-frame rails and be parallel with the centerline of the sub frame rails. A distance of 37 inches will be maintained from the top idler arm bolt centerline to the front frame kick-out with a vertical height of 14 inches (+/-) 1/4 inches. The GM-METRIC TUBULAR REPLACEMENT FRONT SUB-FRAME MUST WEIGH A MINIMUM 95lbs. A bare front sub-frame must be submitted to track officials for weigh in and approval. Front sub-frame must be acceptable to track officials before it can be used in competition.

Part # JCI 09-011 is an APPROVED front sub-frame. Part # GHC-2254 (Amandrel Bent) is also an approved sub frame.

Stafford will allow the following X-Y-G frame replacement parts. The front sub frame, the rear clip from behind the rear spring pockets, as is already approved according to rule 20F-11 letter C. If any part of the frame from the back of the front sub frame to the front of the rear spring pockets. These parts must be replaced with stock OEM GM frame sections.

### 20F - 12.1 Coil Springs

All downward chassis movement while the race car is in competition must be limited only by the normal increasing stiffness of the springs or the bottoming of the chassis against the race track, whichever occurs first. Any travel limiting device or procedure" i.e." (chains or cables) that in the judgment of Track Officials attempts to detract from or compromise the above will not be permitted. This will also include the limiting of any natural upward movement.

All coil springs must be constructed using round magnetic steel wire. Ovate and flat wire will not be permitted. The coil spring wire diameter must be the same size from the top to the bottom of the springs. All of the coils in a spring must be active. The coil springs in all four (4) wheels must be active in any and all suspension movement.

#### B. Front Coil Springs

(1) The front coil springs must be heavy-duty magnetic steel and must be constructed the same as the OEM spring.

(3) The free height of the bare front coil springs must not be more than 11 inches and must not be less than 8-1/4 inches.

(4) All front coil springs must maintain a minimum outside diameter of 5-1/4 inches and a maximum outside diameter of 5-3/4 inches.

(9) One (1) spring rubber insert, not to exceed one (1) full coil, acceptable to Track Officials will be permitted.

#### C. Rear Coil Springs

(1) The rear coil springs must be heavy-duty magnetic steel and must be constructed with both coil ends closed and ground. The closed ends of the coil spring must not have a gap larger than 1/8 inch (3) The free height of the bare rear coil springs must not be more than 15 inches and must not be less than 10 inches.

(8) One (1) spring rubber insert, not to exceed one (1) full coil, acceptable to Track Officials will be permitted.

(9) All coil springs must maintain a minimum outside diameter of 4-3/4 inches and a maximum outside diameter of 5-1/4 inches.

### **20F- 12. 2 SWAY BARS**

A. Only stock, OEM, type, or stock, OEM, type replacement, steel sway bars with a maximum diameter of 1.25 inches may be used in the front and/or rear. Front sway bars must be mounted under the front sub-frame.

B. Bump pad configurations are permitted. Splined sway bars and arms are not permitted.

C. Rubber bushings may be replaced with metal bushings or eye/lollypop type mounts.

D. Heim joints (spherical rod ends) may be used for attaching the sway bar to the lower A-frames.

### **20F- 12. 3 SHOCK ABSORBERS**

A. All shocks subject to Speedway approval. One shock per wheel.

B1. KONI shocks with the following part numbers #30-7325, #30-7436, #30-7647, #30-9325, #30-9436 and #30-9414 are the only shocks that will be permitted. Any Koni shock with a Schrader valve will not be permitted. Any KONI shock that does not have the five (5)-way crimp sealing system will not be permitted.

B2. Any Koni shock that has been found with alterations to the shaft for a performance advantage will be deemed illegal.

C. Rear shocks must be mounted to the crossmember within the frame rails.

### **20F- 12. 4 A-FRAMES**

A. Lower A-frame must be OEM stock in stock location for the chassis being run. No cutting, moving or reinforcing of lower A-frames. The only approved aftermarket lowers will be the Johnson Chassis part numbers JCI-09-02-001 (L-R) & JCI-09-02-002 (L-R).

B. Upper A-frames may be stock or nonadjustable tubular magnetic steel.

C. Ball joints may be replaced with standard factory stock OEM production Chrysler screw-in type or standard factory stock OEM production Chrysler screw-in type direct replacement ball joints in the stock location on the A-frames. Ball joint end of A-frames only may be cut for clearance purposes only, when Chrysler screw-in type ball joint is used.

D. Adjustable, serviceable and "mono" ball joints are not permitted.

E. No adjustable upper or lower A-frames allowed.

F. Upper A-frame cross bar may be aluminum.

G. Rubber bushings may be replaced with metal but cannot be offset.

### **20F- 12. 5 SPINDLES AND HUBS**

A. One-piece nonadjustable, heavy-duty magnetic steel after market spindles with unaltered stock pin must be used. Both left and right spindles must be of the same make, design and offset.

B. Off set spindles are not permitted. Both left and right spindles must be of the same make, design and offset with the same measurement. The measurement from the top of the bottom mounting surface to the bottom of the top mounting surface must be the same from side to side.

C. Heavy duty, magnetic steel, tapered wheel bearings must be used.

C1. No low drag spindle or hub kits, or not part of low drag kits (i.e. spacers) will be permitted.

D. Wide Five or Grand National hubs are not permitted. A steel or aluminum aftermarket hub with GM configuration is permitted. Any other material, i.e. magnesium, will be deemed illegal.

E. Stock track width and offset must be maintained.

F. Only tapered fit, non-threaded, tie rod mounts are permitted. Bolt on steering arms are permitted and must be made of magnetic steel.

G. All steering components must be made of magnetic steel including but not limited to, tie rods, drag links, pitman arms, idler arms, steering arms, and steering boxes.

**G-1.** A stock center link or a stock type replacement is allowed.

**G-2.** A adjustable center link is also permitted.

Approved P/N are-The Johnson Chassis part number

JCI-09-02 Series Billet steel center link

ALL Star Performance-#ALL56330

**H.** For other steering rules see the NASCAR rule book section 20F-13.

**20F- 12. 6 TRACK WIDTH** - Maximum track width measured outside the tire bulge at wheel center height is 73 ¾ inches. Steel or aluminum spacers will be permitted to utilize the maximum allowable track width. Spacers, if used, must be the same thickness left and right, however, the front and rear do not have to match.



for approved fuel cells at Stafford Motor Speedway are as follows: ATL Super Cell "100" FBI - Series Bladders. (Note: the complete cell will be the SU1- Series), and the Fuel Safe Sportsman Cell (SM Series). Any cell that is rated above these cells (ATL 200 & 500 series), and the Fuel Safe Pro Cell (PC Series), will also be approved for competition at Stafford Motor Speedway.

**20F- 16.2 FUEL CELL CONTAINER** – See NASCAR Rule Book

**20F- 16.3 FUEL CELL / FUEL CELL CONATINER INSTALLATION** – Trunk floor may be removed and fuel cell container installed in the opening centered between the frame rails with a MINIMUM 8-inch ground clearance with the car's frame set on five inch (5") high blocks under all four outer corners of the frame.

**If a reinforcement bar is installed per NASCAR rule book 20F-16.3 section H. the maximum distance permitted from the center of the rear axle to the center of the reinforcement bar is 37½ inches. For additional specifications see the NASCAR Rulebook.**

**20F- 16.4 FUEL FILLER / VENT REQUIREMENTS** – See NASCAR Rule Book

**20F- 16.4.1 FUEL FILLER** – A twist in fuel filler cap assembly bolted from the inside of the left rear quarter panel and located in the side as high and as far back as possible OR on top as far to the left as possible but not in the deck lid is allowed. See NASCAR Rulebook.

**20F- 16.5.3 FUEL SHUT-OFF** – A 1/4-turn fuel shut-off valve of minimum 3/8-inch NPT with minimum 4-inch handle is required in the fuel line. The fuel shut-off valve must be located 8-inches inboard of the passenger side frame rail's outside edge and 24-inches forward of the main roll bar (#1 bar). The fuel shut-off valve must be mounted securely to the under side of the driver's compartment sheet metal. The fuel shut-off valve shank must protrude through a maximum 1-inch diameter hole in the sheet metal to the interior of the driver's compartment. The fuel shut-off valve handle must be parallel with the sheet metal that the valve is mounted to. The fuel shut-off valve handle must be a minimum of 4-inches in length, red in color with a minimum of 1-inch clearance from the sheet metal throughout its full travel. A minimum 6-inch by 6-inch square area must be painted white with the fuel shut-off valve's ON and OFF positions clearly labeled with 1/2-inch tall, black in color lettering. The shut-off valve must rotate clockwise from a ON position with the handle parallel with the frame rail, pointing towards the rear of the car, to the OFF position with the handle perpendicular to the frame rail pointing toward the driver.

**20F- 17. 4 ROLL BARS** - See NASCAR Rulebook. The following are additional requirements and clarifications for the installation of roll bars. **NOTE: For all non or parcel X-Y-G cars these measurements must apply NO EXCEPTIONS! (These cars will be grand fathered into the new NASCAR rules & these cars will be able to be used as Limited Late Model or DARE Stocks).** All NASCAR Rule Book specifications must be followed. No plating of the frame. A maximum of 38.875 inches from the center line of the front lower ball joints to the centerline of the roll cage front legs (referred to as bar #2a & #2b) will be permitted. A maximum of 82.625 inches from the centerline of the front lower ball joints to the centerline of the main roll bar (referred to as bar #1) will be permitted. The main roll bar must be mounted vertical (90 degrees) on the center section of the frame with no offset or setback. The #1 bar must be centered to the chassis. The roof bar (referred to as #3) must be within 4" of the side window and/or door openings on both sides, as well as the front windshield. All roll bars must follow the contour of the body. The #2A & #2B bars must be no more than two (2) inches behind the length of the A-pillar in the stock location.

**Positively no offset or setback roll cages!!!!**

**NOTICE** – Competitors are solely and directly responsible for the safety of their race cars and racing equipment and are obligated to perform their duties (whether as a car owner driver or crew members) in a manner designed to minimize to the degree possible the risk of injury to themselves and others.

**NOTE ALL VERTICAL BODY MEASUREMENTS ARE OFF RIDE HEIGHT. AND ALL OTHERS ARE OFF 5" BLOCKS NO EXCEPTIONS.**

**CONTINGENCIES.** Contingency Sponsors are a valuable part of Stafford Motor Speedways program.

Contingency stickers must be displayed for either product or monetary considerations. Each division will be notified as to what stickers are required to be eligible for contingency rewards. The stickers MUST be displayed on both sides of the car. In particular, the decals must be mounted on the driver's side of the car in such a manner that they are CLEARLY VISIBLE in a photograph.